

# COURT-CUSTODY AUDIO VISUAL LINKS

*Designing for equitable justice  
experiences in the use of court-  
custody video conferencing*

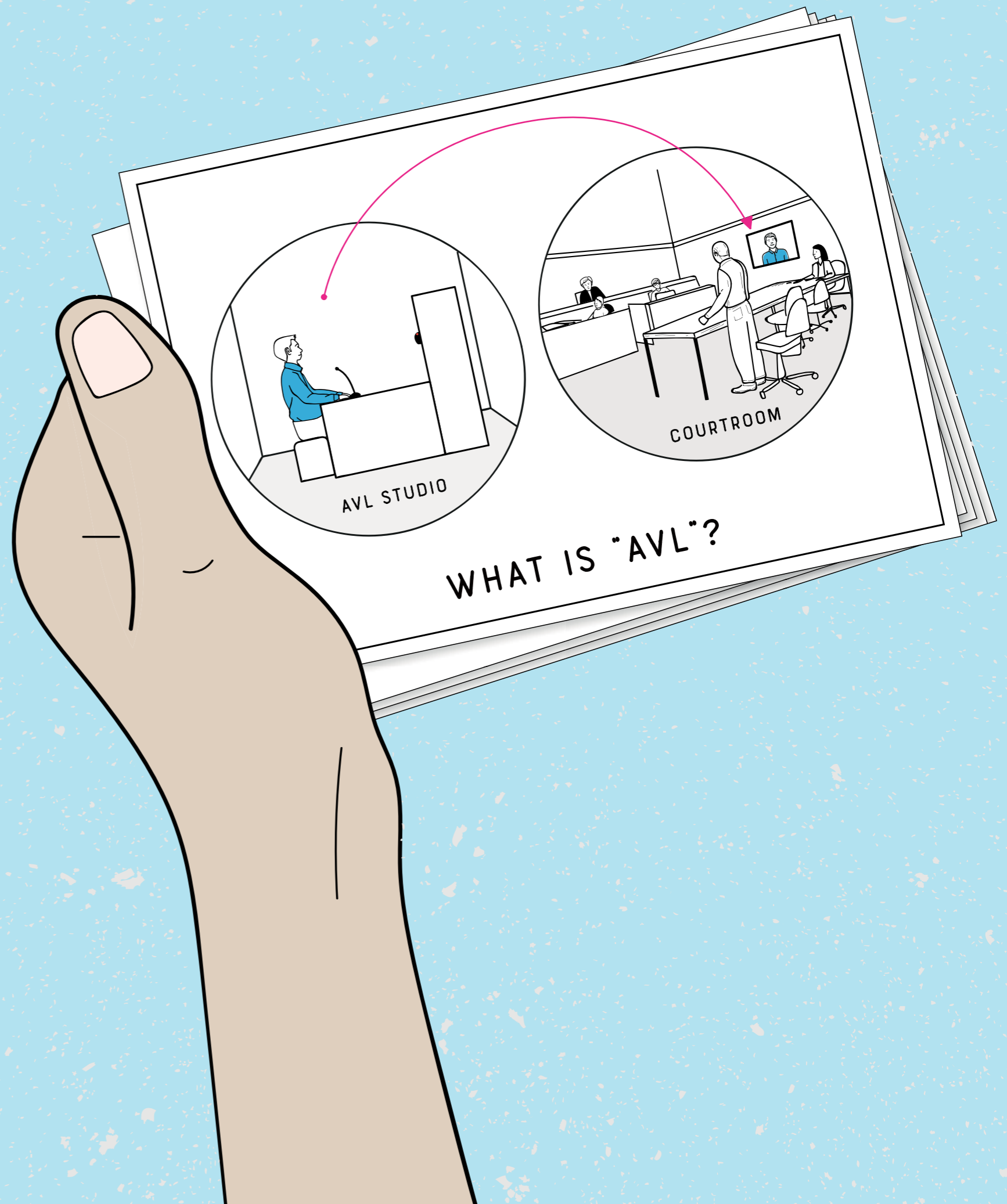

Justice NSW • Designing Out Crime Research Centre  
September 2017





---

This is a collaboration between the NSW Justice Department's AVL Project Group, its stakeholders across the NSW Department of Justice and the Designing Out Crime research centre (DOC) at the University of Technology Sydney (UTS) in September 2017.

## Enquiries

---

Dr. Rohan Lulham  
Designing Out Crime Research Centre  
Level 3, 235 Jones St, Ultimo  
University of Technology, Sydney

**Postal address:**

PO Box 123 Broadway NSW 2007 Australia  
Email: rohan.lulham@uts.edu.au  
Telephone: (+61) 411 640 289  
Web: [www.designingoutcrime.com](http://www.designingoutcrime.com)

## Authors

---

Dr Rohan Lulham, Project lead  
Kiran Kashyap, Design lead and co-ordination  
Lucy Klippan, Design lead  
Tasman Munro, Design lead  
Douglas Tomkin, Design strategy  
Kevin Bradley, Architecture lead  
Jack Fahy, Design lead  
Chan Woo Park, Animation design  
Dr Emma Rowden, Architecture research expert  
Dr Carolyn McKay, Law research expert

## Contributors

---

**NSW Justice AVL Project:** Hanlie Botha, Wendy Johnston, Carol Carter, Helen Reynolds, Christopher Lord, Graeme Corbett, Anna Edwards, John Murphy, Kate Goodwin, Patrick Donoghue  
**Corrective Services NSW:** Peter Sharp, Gregory Field, facility staff, defendants  
**Juvenile Justice NSW:** Gerard Hughes, facility staff, defendants  
**Court Testing:** Magistrates, Police prosecutors, LegalAid lawyers, court staff  
**Experts:** Mary Woodward

# Contents

---

<b>INTRODUCTION</b>	<b>4</b>	<b>AVL STUDIO DESIGN</b>	<b>35</b>	<b>CONCLUSION &amp; RECOMMENDATIONS</b>	<b>50</b>
Introduction.....	5	Introduction to Concept.....	36		
Methodology.....	7	Design Attributes.....	37	<b>ENDNOTES</b>	<b>53</b>
		View of Defendant.....	38		
<b>CONTEXT &amp; RESEARCH</b>	<b>8</b>	Design Component Details.....	39	<b>TEAM</b>	<b>55</b>
Literature Review.....	9				
Design Research.....	12	<b>AVL FACILITY ARCHITECTURE</b>	<b>40</b>	<b>APPENDICES</b>	<b>56</b>
		Concept Background.....	41		
<b>FRAMING</b>		Design Considerations.....	42		
<i>Finding Your Way - Navigating the AVL Court Process</i>	<b>18</b>	Facility Design Plan.....	43		
		Concept Render.....	44		
<b>DESIGN</b>	<b>23</b>				
<b>ORIENTATION RESOURCES</b>	<b>24</b>	<b>APPEARING IN COURT</b>			
Introduction.....	25	<i>The Interface Design</i>	<b>45</b>		
AVL Guide Cards.....	26	Introduction to Concept.....	46		
Book of Legal Words.....	28	Design Attributes.....	47		
Personal AVL Notebook.....	30	Technological Considerations.....	48		
Pre-Connection Video.....	31	Proposed Onscreen Layout.....	49		
Sense-Making Signage.....	33				

# Introduction

---

# Introduction

## What is an Audio Visual Link?

Within the NSW justice system an Audio-Visual Link (AVL) refers to the use of video conferencing equipment to link people in two different locations. In NSW most courts and custodial facilities in the adult and juvenile jurisdictions have audio-visual link (AVL) facilities. The use of AVL for people to appear in court from custody has increased dramatically over the last five years in both the adult (64.4%) and juvenile jurisdictions (63%). It is critical to the operation of the NSW justice system that the experience of AVL court appearances supports and enables people's participation in the effective and fair administration of justice.

## The Project

The aim of the project is to develop strategies to improve the experience of all participants involved in Audio Visual Link appearances between court and correctional facilities in the juvenile and adult jurisdictions. The project represents Stage 2 in a program of work undertaken by the UTS Design Team for the Justice Department's AVL Project Group. In Stage 1 basic ergonomic and technical recommendations for AVL Studios in custodial contexts were developed, through a thorough literature review and user testing. In this project, Stage 2, we extend and build on this work with a focus on designing better, more equitable AVL experiences in the NSW justice system. A holistic system based approach was employed to consider the technology and infrastructure at both ends of the conversation (court and custodial contexts), as well as supporting information to guide defendants within the process.



## Brief

The brief for this project was to improve the experience of all participants involved in AVL appearances between court and correctional facilities in the juvenile and adult jurisdictions through:

- engaging stakeholders in a collaborative co-design process
- drawing strongly on the conceptual frameworks (equality of experience, procedural justice), our observations and the research literature
- establishing a productive framing, or way of the thinking about AVL in the justice system, to inform efforts to improve the system; and
- developing specific resources, facility designs and recommendations to meaningfully improve and change people's experiences.

## Scope

The final agreed scope for this project has three general areas of focus:

- orientation resources for custodial AVL participants
- interior and architectural design of custodial AVL facilities
- court-custody interface design

## Orientation Resources

Orientation resources were developed for the adult and juvenile context. A specific refinement process was undertaken to refine the resources and how they would be used in the juvenile context with young people. Similar general types of resources were created for adults and young people including:

- AVL Guide Cards
- Book of Legal Words
- Your AVL Notebook
- Pre-Connection Video
- Sense-Making Signage
- Narrated Preparation Video

## AVL Studios in Juvenile and Adult Custody

Detailed exemplar interior designs were developed for AVL studios in juvenile and adult custody. These designs drew heavily from the Stage 1 technical and ergonomic study and closely considered equitable justice processes and the related design research. This includes:

- cabinetry and seating
- fixtures and lighting,

- studio dimensions
- treatments to the walls and floors
- technical AVL equipment set-up
- signage

AVL support facility in juvenile custody: Concept designs were developed for an AVL support facility within juvenile custody. A new hypothetical site was identified for an AVL support facility at Cobham Juvenile Justice Centre. Using this site, and the close involvement of AVL staff and JJC staff, we developed concept plans, elevations and basic renders of the design. The modular and attached design of this facility has also created design concept that can be easily adapted and developed for other JJs. The AVL support facility includes:

- staff offices
- court-custody AVL studios
- legal AVL studios
- waiting and holding areas;
- circulation spaces

Design concepts for an adult AVL support facility were outside of the scope of the project, however some recommendations are made in relation to the current adult AVL support facilities.

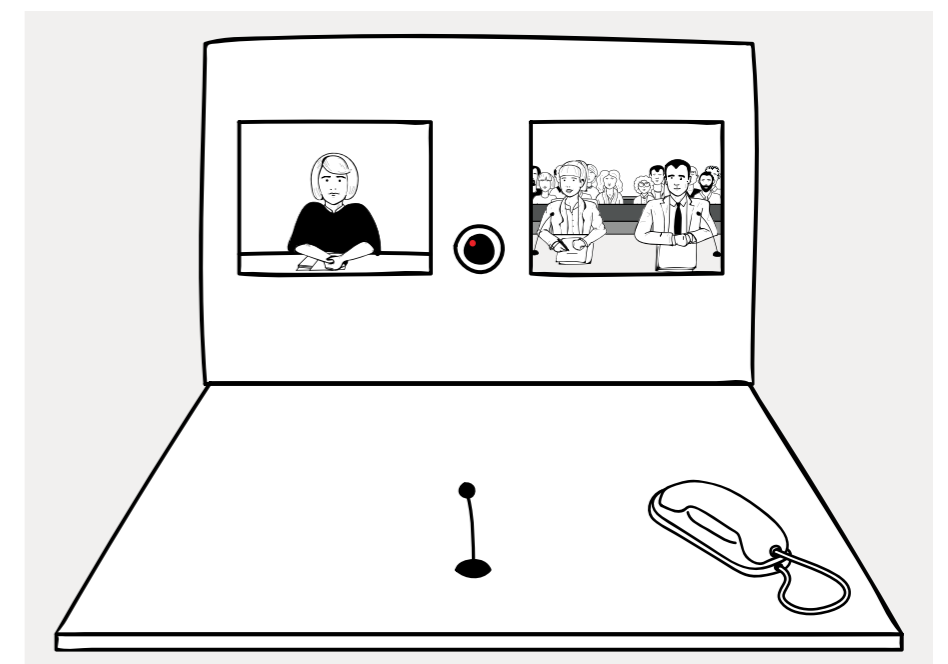

# Introduction

## Court-Custody Interface Design

Investigate and provide initial recommendations on the design and configuration of the AVL equipment interface within courts and its impact on the experience of court and custody participants. This included investigating the relationships between:

- position of the display screen(s) and the cameras within the court
- judicial officers view and experience of the person in custody on-screen
- legal representatives' view and experience of the person in custody on-screen
- person in custody's view of the legal representatives, judicial officer and courtroom gallery

In addition, recommendations and design concepts were developed for the screen layout on the display viewed by the person in custody. The court-custody interface design component was not specific to adult or juvenile jurisdiction.

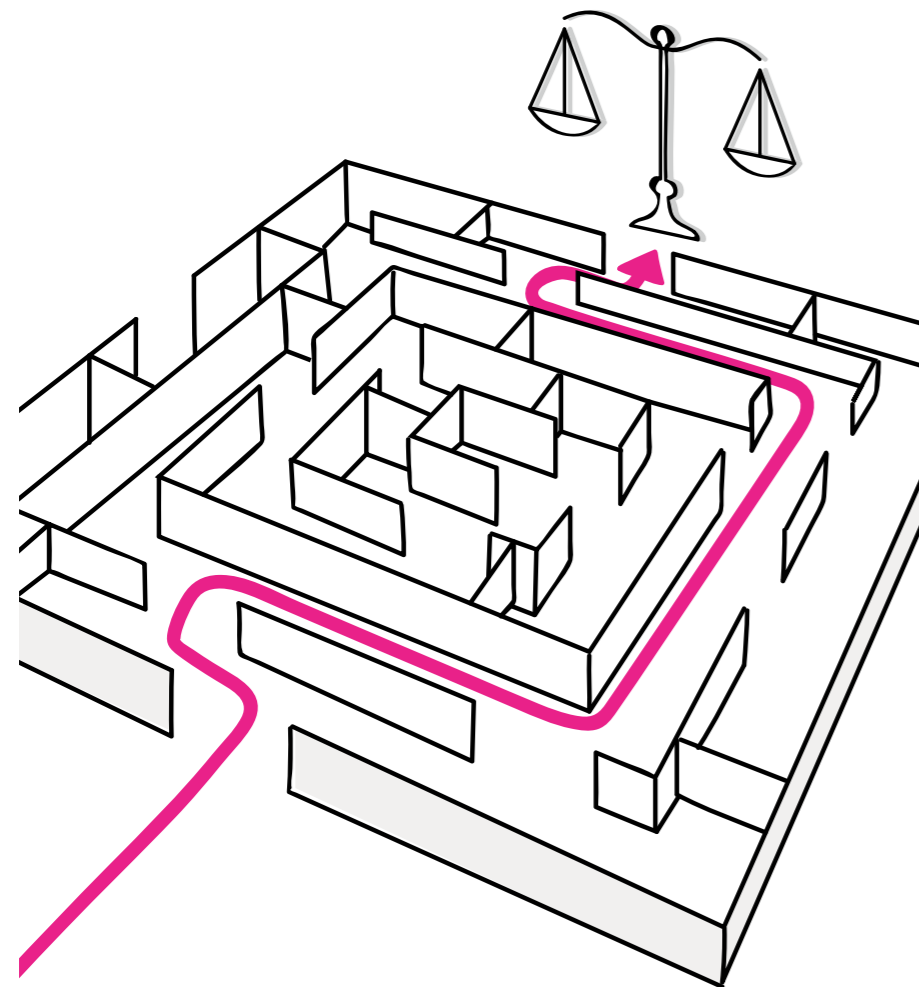

## Design Team

We are an established multi-disciplinary design research team based at UTS who have delivered innovative and practical solutions in a range of complex justice projects. Dr Rowden and Dr McKay join us with world-leading expertise on the design and the legal considerations relating to the use and experience of Audio Video Links in the justice system. The team has expertise in research, workshop and conceptual skills related to the design and operation of justice facilities. Our backgrounds range from design, architecture, criminology, visual arts to law and psychology. The team working on this project includes:

- **Dr Rohan Lulham**  
Expertise in design research, forensic psychology and environmental psychology within justice contexts
- **Kiran Kashyap**  
An industrial and graphic designer, with experience leading the graphic design and participating on a range of social design projects
- **Lucy Klippan**  
Visual artist and designer with over five years experience working on innovation and social design projects
- **Associate Professor Douglas Tomkin**  
Over forty years' experience in design research and strategy development in a range of contexts
- **Kevin Bradley**  
Architect with correctional facility design research experience
- **Tasman Munro**  
An industrial designer with unique expertise in social design and designing with Indigenous communities
- **Dr Emma Rowden**  
A Chancellor's Postdoctoral Research Fellow in architecture at UTS whose research has informed the creation of design guidance influencing the implementation of court videolinks internationally
- **Dr Carolyn McKay**  
Criminal law/procedure lecturer at Sydney University Law School who has conducted detailed research into NSW prisoners' experiences of using AVL to access justice. Carolyn is also audio/visual media artist
- **Jack Fahy**  
Industrial design student with interests and specific skills in a service design approach to social and complex problems

## Deliverables and Implementation

The project deliverables are this report; the accompanying graphic and drawing files for each of the resources and/or designs; and where relevant, two sample copies of the resources printed on standard paper.

### This Concept Report:

- provides an overview of the methodology, design research and observations that inform the resources
- introduces a way of framing AVL in the justice system that offers a productive way to look at improvements to the experience of system users.
- articulates each of the AVL resources and design concepts developed in the project, and
- states general recommendations.

A full inventory of the products delivered in this project and the associated file names are provided in the Appendix 1. Accompanying this report is a USB drive which has folders with the associated artwork for each of the products.

Implementation of the resources and designs is a clear intention of the Justice stakeholders and UTS design team working on this project. While implementation is outside of the scope of the current project and funding, where feasible the UTS design team is willing to collaborate and assist in the implementation of the resources, designs and recommendations. In this regard we will include where relevant recommendations around implementation in the report.

# Methodology

---

## Our Approach

---

Our approach involves applying collaborative design research methods to develop frameworks and strategies in a range of organisational and social contexts. In this project we utilised a co-design process to understand the context, introduce the relevant research literature and identify key themes to inform the development of the strategies. This process enabled us to identify concepts that integrate and respond to the key concerns and objectives of the justice system, its stakeholders and users. The process of developing the design concepts was iterative and drew strongly on the knowledge, expertise and experiences of stakeholders and users.

## Design Process

---

### 1. Clarify the brief & project set-up

*Engage the clients and key stakeholders to clarify the agreed initial brief, the design process and requirements*

### 2. Context research

*Primary research with stakeholders/user groups sites visits, precedent study and literature summary*

### 3. Identify good practice and framing the spaces

*Stakeholder and internal workshops to frame the purpose and use of the spaces*

### 4. Design development

*Iterative design development process that utilised workshop processes to develop and validate the designs:*

- **Concept generation**

*Initial concepts based on research, framing and design processes*

- **Co-design**

*Design workshops with stakeholders and users. Initial design concepts may be used as a probe*

- **Co-refine**

*With stakeholders refine design concepts to establish a set of agreed designs*

- **User testing**

*Enable formal testing / validation if undertake by client*

### 5. Reporting

*Documentation of the research, framing and design concepts in the project*

## Site Visits

---

### Correctional Centre (Adult)

- Mid-North Coast Correctional Centre
- Metropolitan Special Programs Centre
- Bathurst Correction Centre (onsite study and video conference)
- Silverwater Women's Correctional Centre (onsite study and video conference)
- Dillwynia Correctional Centre for women

### Juvenile Justice Centres (Young People)

- Cobham JJC (five separate visits)
- Parramatta Children's Court custodial area

### NSW Court Facilities

- Parramatta Children's Court (view court, consult court & legal)
- Downing Centre Court complex (observe courts, court tour, remote witness area, observe arraignments)
- Central Court (observe courts three times, court tour, observe interpreter AVL involvement)
- Industrial Relations Commission Court (view, modify and test different court interface setups with relevant stakeholders)
- District Court
- Supreme Court

## Design Research Studies

---

### Basic Ergonomic and Technical study

This is the Stage 1 project that had the purpose of developing basic ergonomic and technical recommendations for custodial AVL studios (Lulham, Kashyap and Rowden, 2016). The study involved a review of the practice and academic literature on AVL type environments and, where key parameters could not be easily determined from this literature, semi-formal testing using a full scale AVL studio mock-up. The recommendations covered the spatial qualities (room size, furniture/ fixture placement), environmental qualities (lightening, acoustics, etc) and AVL equipment set-up (screen, cameras, microphone).

### Orientation Study – Bathurst Correctional Centre

Overseen and facilitated by the Manager Video Conferencing CSNSW, a specific study was undertaken to develop the understanding of people's experience of AVL from custody. This included talking with AVL custodial staff and a number of defendants who were waiting in a holding area in relation to an AVL appearance. It included discussions about what resources or information would assist them in engaging and having a better experience as a participant in an AVL hearing. Information from the study informed the framing, selection and design of the strategies.

### Court Interface Study – Industrial Relations Court

This study investigated the impact of different positioning of the AVL display screens and cameras in the courtroom. Specifically it investigated the impressions from the perspective of the judicial officer and the legal representative in court, and the view seen by a defendant in custody. This was investigated based on the current camera and screen position and two alternative configurations. A small number of court staff, judicial officers and legal representative with extensive experience separately viewed the different configurations and participated in discussions around the merits and preferences for each. This knowledge informed the development of court interface concept designs and recommendations.

## Ethics Clearances

The methods used in this project are typical of most design projects. We have UTS Human Research Ethics coverage of this project through the DOC ethics program approval. Our intention for this project was to obtain ethics approval with all organisations involved in this research ( Justice NSW; CSNSW; Juvenile Justice). There were a number of delays and disruptions in this project that impacted on when it started and its progress in the early stages. This resulted in an 8 month project being compressed into 4.5 months. The CI made a decision that obtaining specific research ethics approval from each organisation would not be possible with these time frames. The previous experience was it taking 5 months with one organisation. We did, however, follow our ethics processes including ensuring informed consent where relevant. As a result, while considerable design research was conducted, without these clearances we can not publish or report specific findings related to the research. This is regrettable but unavoidable under circumstances.

# Context & Research

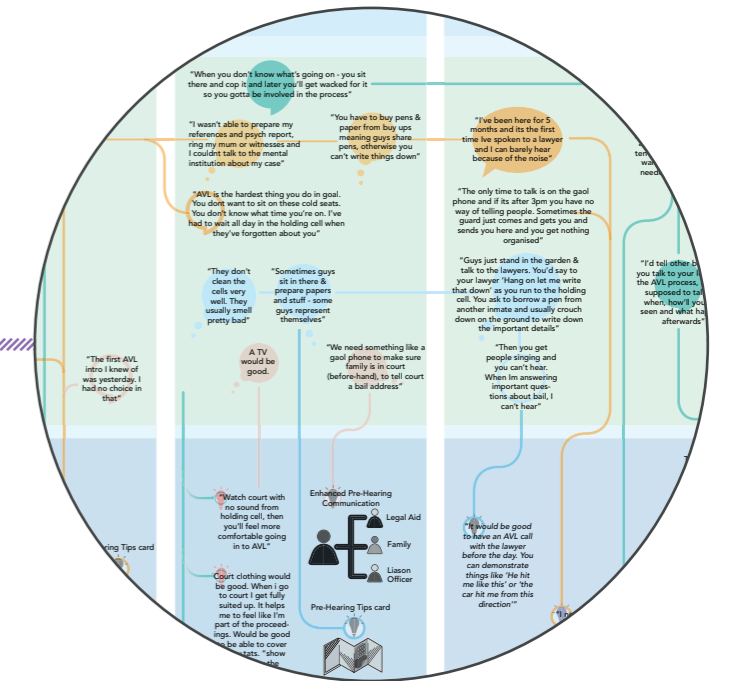



# Literature Review

## Overview

Because AVL is now used for 64.4% of adult court appearances, 100% of parole appearances,<sup>1</sup> and over 63% of juvenile justice court matters,<sup>2</sup> it is critical that AVL suite design should reflect procedural justice values as well as the values-led culture of the Department of Justice.<sup>3</sup> The following provides a brief overview of research that reveals key issues for designing AVL suites. What does the evidence suggest regarding AVL spaces and the values they should they reflect? As the use of AVL for incarcerated defendants (hereinafter referred to as prisoners) is a fairly recent innovation in criminal justice, relevant literature and empirical evidence regarding the impact of its use is limited.<sup>4</sup>

There is a body of research that examines the use of AVL ‘remote witness facilities’ that may be relevant to the use of AVL suites for linking prisoners to other parts of the justice system. Most significant is the 2013 Gateways to Justice project, as well as affiliated doctoral studies,<sup>5</sup> that formulated design and operational guidelines for AVL spaces.<sup>6</sup> AVL facilities must be designed in the context of the governing legislation,<sup>7</sup> the built environment of the remote site (such as a the security needs of a prison), court procedure and ritual, training of relevant staff in all sites, and the configuration of the AVL technology.<sup>8</sup> Of relevance to custodial AVL suites, ‘remote participants’ such as prisoners should be framed by the technology in a manner that does not diminish their appearance and furthermore, it should demonstrate that they are being treated with dignity, humanity and respect.<sup>9</sup> AVL proceedings should maintain ‘formality, decorum, and solemnity of proceedings’<sup>10</sup> and such values should extend to the whole AVL vicinity including waiting areas and holding cells.<sup>11</sup> Therefore the challenge is to design AVL physical and virtual environments that maintain fundamental values of impartial and democratic public procedure.<sup>12</sup>

In essence, prisoners must be afforded a just, fair and humane environment for court appearances by AVL, in a non-prejudicial manner that does not compromise the presumption of innocence.<sup>13</sup> As much as possible, the prison AVL suite should therefore reflect and enable procedural justice, being: (i) voice – the ability of parties to expressively participate; (ii) neutrality – transparency and consistency in decision-making and lack of bias; (iii) respect – individuals are treated by the state with dignity; and (iv) trust – a belief in authorities as trustworthy.<sup>14</sup> As previously mentioned, such values align with those of the Department of Justice. Results from procedural justice research have also

consistently found that there is a considerable social consensus that exists amongst people – regardless of age, gender, education, income, ideology or ethnicity – as to what constitutes fair procedure; this stands in contrast to notions of what constitutes a fair outcome in any given case, which can vary widely between these groups.<sup>15</sup> To embed procedural justice values within a correctional facility is not without its challenges given the disparate nature of the space of state incarceration versus the civic and open nature of most courthouses.<sup>16</sup> Overseas models suggest the possibility that custodial AVL suites can mirror the courtroom environment.<sup>17</sup> Recent initiatives in Europe have sought to improve both the technology as well as the environment in which the audio visual experience takes place. Recent initiatives in Europe have sought to improve both the technology as well as the environment in which the audio visual experience takes place.<sup>18</sup>

The Gateways to Justice researchers found that the placement of screens, cameras and microphones are critical to the quality of the images and sounds transmitted between sites and to the user experience of the remote witness/prisoner.<sup>19</sup> From the courtroom endpoint, screen size can impact perceptions of evidence or testimony.<sup>20</sup> From the prison endpoint, the small screen size and fixed camera angles in existing AVL suites impact prisoners’ abilities to recognise their distant lawyers, view documentation/briefs or evidence, have an awareness of eye contact, see family members in the public gallery and fully participate or comprehend their legal matters.<sup>21</sup>

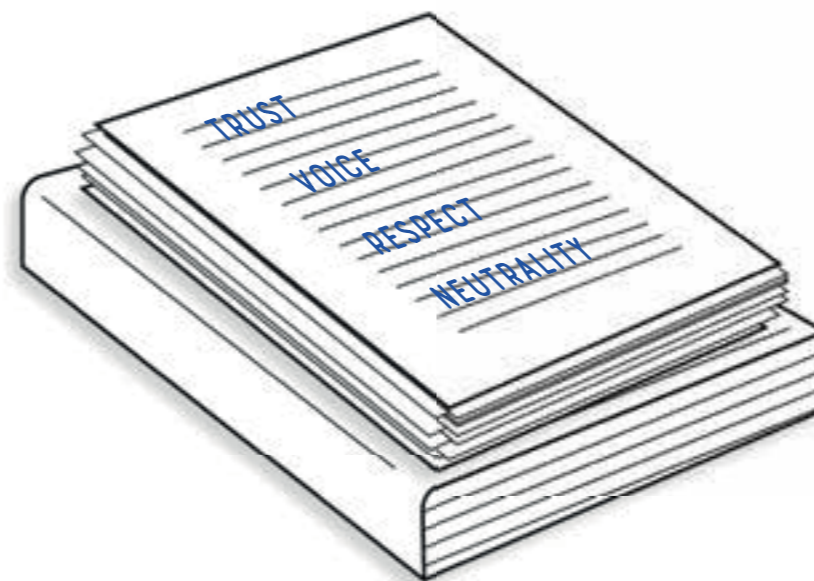

It is also worth noting research concerning the unique difficulties faced by prisoners who require translator services during AVL court appearances. Screen size and fixed camera angles are design issues that particularly affect prisoners in such situations.<sup>22, 23</sup> Furthermore, the linguistic, nonverbal communication and cultural requirements of incarcerated Aboriginal people have been raised as issues for AVL suite design and technological configurations.<sup>24</sup>

AVL studios need to ensure access to justice for prisoners given the physical separation between prisoner and lawyer, the very significant usage of AVL by Legal Aid NSW for legal conferencing<sup>25</sup> and the implicit power imbalance between prisoner and the state. Related to access to justice is the issue of soundproofing and associated audio bleed, that is, the unintended transfer of sound either out of the AVL suite, or the transfer of external and ambient sounds into the AVL suite from the surrounding prison environment has been noted in empirical research.<sup>26</sup> Poorly soundproofed suites that permit prisoners’ conversations to be overheard compromise the privacy and confidentiality of legal conferencing. Similarly, suites that allow the infiltration of ambient prison noise affect prisoners’ abilities to concentrate and may be transmitted to the remote courtroom, distracting judicial officers and potentially framing the prisoner in the context of an anti-social environment.

The design of the remote suite and its technology can play a vital role in both presenting the prisoner in an appropriate manner, as well as increase their comprehension of the nature of the encounter being facilitated. Ultimately, design issues and technological problems related to screens, camera angles, soundproofing and audio visual interfaces can frustrate prisoners, potentially impacting their comprehension of and meaningful participation in their court proceedings,<sup>27</sup> with the potential to create disharmony during or following AVL sessions. In summary, the key values that custodial AVL suites should reflect include procedural justice (encompassing fairness and impartiality), access to justice, humaneness, dignity and respect.

# Literature Review

## Framework and Approach for Designing Custodial AVL Suites

Based on our literature review we provide the following framework and approach to custodial AVL suite design.

### (i) Custodial AVL Space As Court Space

The use of AVL has radically altered legal space for prisoners as, under NSW law, a custodial AVL suite (including various prescribed police and court cells)<sup>28</sup> is considered to be part of the court space<sup>29</sup> and the judicial officer has responsibility and oversight of the custodial AVL suite including holding participants to the same expectations of appropriate behaviour as in the courtroom. Therefore a principle of 'equivalence to' or 'improvement upon' the in-person experience of court proceedings should prevail for a prisoner's AVL connection within the custodial AVL suite.<sup>30</sup> Achieving equivalence of the in-person court experience in the conceptual extension of the courtroom into the correctional facility<sup>31</sup> is challenging and requires careful consideration of the design of the technology, the built environment, the legal and physical processes as well as the training of correctional and court staff and the enactment of judicial rituals.<sup>32</sup>

What is court space and what is it to attend court by AVL from a custodial suite? There is a large body of literature that examines the nature of courtroom space<sup>33</sup> and while such literature identifies the inherent hierarchies and segregation zones of courtroom design, it also emphasises its dignified, public and civic qualities.<sup>34</sup> By comparison, AVL suites are enclosed in the 'hardened corrections endpoint'<sup>35</sup> that is non-public and does not currently replicate courtroom design, providing a significant spatial and experiential disjuncture in legal procedure.<sup>36</sup> Instead, the aesthetic qualities of the surrounding prison shape prisoners' legal experiences.<sup>37</sup> Through the cumulative changes to the space of court appearance and access to justice brought by the use of AVL, the enactment of justice is fundamentally altered, giving rise to prisoners' problems in communicating with remote courtrooms and lawyers, diminished comprehension, less ability to expressively participate in their own legal proceedings and perceptions of inequality.<sup>38</sup>

### (ii) Spaces Must Enable Procedural Justice

As discussed above, custodial AVL spaces ought to reflect the key values of procedural justice (including fairness and impartiality), access to justice, humaneness, dignity and respect, as well as the Department of Justice's own values-led culture in its workplaces.<sup>39</sup> Whether the design and operation of an AVL suite enables the effective and fair administration of justice can be conceptualised and assessed against the principles of procedural justice.<sup>40</sup> In multiple studies, it has been shown that participant's perceptions of neutrality, respect, fairness, and the opportunity to have a voice and be heard, are shown to relate to the success of the justice process. Poorly designed and operated AVL suites are likely to impact negatively on perceptions of fairness, neutrality, the ability to be heard and have a voice, ultimately diminishing overall perceptions of the justness of the system.<sup>41</sup> Moreover, such a situation challenges fundamental common law principles of open and impartial justice, equality of arms and the presumption of innocence, and may critically alter prisoners' legal experiences, their comprehension and abilities to effectively access justice.<sup>42</sup>

In a custodial AVL suite, the court process is communicated through specific AVL equipment (screens, camera, speakers and microphones) situated in particular physical settings (rooms of different sizes, furnishings, acoustic properties, natural or artificial lighting levels). Variations in the set-up of the AVL equipment, how it is used during proceedings and the physical qualities of the AVL suite can impact dramatically on what is experienced, understood and perceived of the court proceedings and how well the prisoner may communicate with their legal representative.<sup>43</sup> The framing of the remote prisoner onscreen, how well eye-contact has been able to be replicated, the extent to which the person has a sense that they are in-court, are all factors that can impact upon the remote prisoner's behaviour and his or her perception of the court experience.<sup>44</sup> While ergonomic considerations affect the experience of AVL participants, there are broader design and operational factors that also impact prisoners' experiences and challenge fundamental legal tenets, and thus need to be considered. This includes the AVL studio needing to reflect the dignified space and furnishings of a courtroom.<sup>45</sup> Within the broader justice system there are therefore tensions regarding the use of custodial AVL suites and remote, as opposed to physical in-person, participation in court proceedings. Concern exists among some prisoners and legal practitioners that appearance via an AVL facility may prejudice the prisoner's bail, appeal or sentencing hearing.<sup>46</sup>

### (iii) The Four Stages of AVL Encounters

To set standards for the appropriate design of custodial AVL space as reflective of a courtroom and the key values of procedural justice, it is productive to examine the daily usage of these spaces and how prisoners pass through and engage with the AVL suites and technology. In this regard, we adopt the approach of the Gateways to Justice project.<sup>47</sup> There are essentially four stages to the 'remote court encounter':

1. **Prior** – what happens before the AVL facilitated court appearance;
2. **Thresholds** – the physical and technological thresholds that the prisoner must navigate on the day of the AVL facilitated court appearance;
3. **The Encounter** – what occurs during the AVL session; and
4. **Afterwards** – what occurs following the AVL session.

#### 1. Prior

This stage involves corrective services staff interacting with scheduling services, remote courtroom administrators and legal practitioners and prisoners. From the perspective of prisoners, prior to an AVL session they will have (hopefully) had contact with their legal representatives either via postal services, telephone or AVL legal conferencing. On the morning of their AVL session, prisoners will be called to the AVL area and placed in a holding cell or other waiting area. Empirical research indicates that prisoners experience considerable frustration prior to AVL sessions when they have not been contacted by their lawyer prior to being called to the AVL holding cells, and when they are called up too

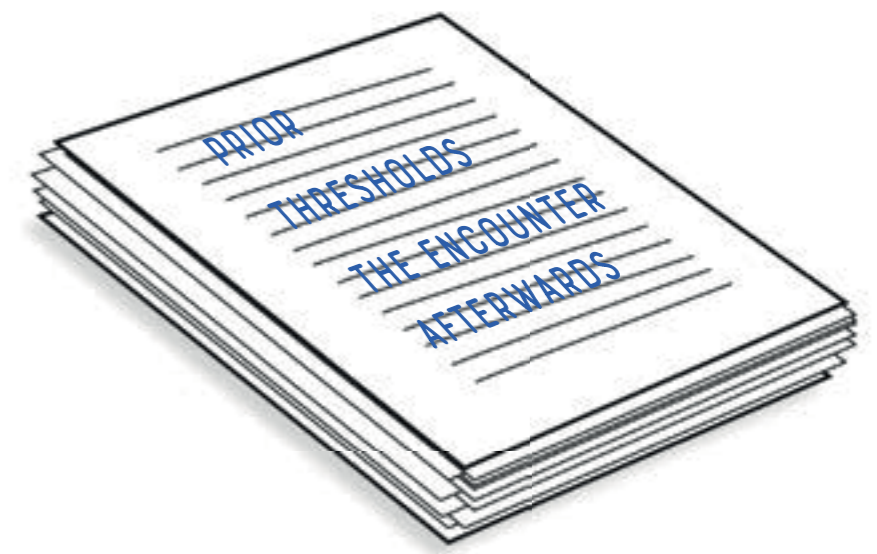

# Literature Review

---

early for their remote court appearance and spend hours of ‘dead time’.<sup>48</sup> While these issues relate to client-lawyer communications and administrative scheduling, they also highlight the importance of the holding cells for prisoners. The holding cells should be considered as part of the AVL facilitated court procedure and therefore be dignified and comfortable spaces with adequate facilities and amenities suitable for long waiting periods.

McKay’s research also shows that many prisoners are not adequately briefed prior to the AVL encounter in terms of how to engage with the technology, where to look, when they are ‘on’ or ‘off’, or how to communicate with their remote lawyer or other courtroom participants, for example, how to use to telephone handset in the AVL suite. As the Gateways project suggested, a simple step-by-step guide ought to be available, especially for those prisoners who may be new to the criminal justice system and for those for whom English is a second language. This briefing and orientation guide could be by way of pamphlet or short video.

Prior to the actual AVL session, the technology ought to be checked by correctional services staff to confirm that both video and audio elements are operational. Furthermore, prior to AVL court appearance, prisoners ought to have the opportunity to groom themselves using a secure mirror and to change into civilian clothing to avoid an unruly and stigmatising appearance.<sup>49</sup>

## 2. Thresholds

On the day of an AVL session, prisoners pass through a number of thresholds from their accommodation through to the holding cells in the AVL area, into the AVL suite and then back to the holding cell to await their release back to their accommodation. As discussed above, waiting in the holding cells can be a very uncomfortable experience for prisoners with many frustrated by the length of waiting time and the lack of information regarding the approximate wait.

From the holding cells, prisoners must then transition into the conceptual courtroom space of the AVL suite. As the Gateways project observed, this transition may be less formal than the experience of attending a physical court in-person. Prisoners require advice from the corrective services staff as well as acknowledgement from the remote courtroom that they have entered court space when they step into the AVL suite. Surprisingly, research indicates that prisoners are often not greeted by anyone in the remote courtroom, leading

to a lack of awareness as to whether the prisoner can adequately hear and/or see, prisoners being unaware as to whether they are ‘live’ and also prisoners’ feeling that they have no part to play in their own legal matters.<sup>50</sup>

To improve this experience, the threshold into the AVL suite requires a design that expressly reflects the formal and dignified courtroom environment. Visual cues of a courtroom environment, such as a secure coat-of-arms or high resolution photographic image on the wall behind the prisoner, and good quality furnishings, would provide a sense of occasion when entering the AVL suite. Verbal cues including the judicial officer greeting the prisoner by name would assist in making prisoners feel acknowledged.

## 3. The Encounter

During the AVL session, it is important that good visual and audio transmissions are maintained and monitored, and any problems with communications immediately rectified. In the same vein, the judicial officers and administrative staff in the courtroom endpoint need to remain vigilant to ensure that the AVL technology is fully operational. Prisoners need to be enabled to communicate with their remote legal representatives and the courtroom, and their view of the courtroom should allow a clear image of the judicial officer, their lawyer and the public gallery.

## 4. Afterwards

The conclusion of the AVL session must be made clear by the judicial officer to the prisoner to ensure that firstly, the prisoner has comprehended the legal procedure, secondly, whether the prisoner has anything further to say, and finally, that the session has finished. A dignified comment such as the following should be made by the judicial officer in conclusion:

*“Thank you Mr/Ms X for attending today by AVL. The video link will be terminated shortly. Do you understand what has occurred today? Do you have any questions? (or ‘your lawyer will contact you to answer any of your questions’).”*

Following an AVL appearance, prisoners must return to the holding cells and await the issuance of a warrant for their release back to their residential cell or workplace. McKay’s research found this was again a period of frustration for some prisoners with extended waiting times in the uncomfortable holding cells.

Other sources of frustration included not being called to attend the AVL session at all, that is, prisoners would often find out retrospectively that the court had proceeded with the hearing in their absence, and secondly, prisoners often had to wait for a long time to be debriefed by their lawyers following their AVL session. Facilities and protocols must be put in place to enable adequate pre- and post- AVL support and conferencing between prisoners and their lawyers.

## (iv) Place In Which People Work

Court environment as work place – issues and needs of everyday users vs. one-off users – UX design and obligations and responsibilities – about judicial officers. The transformations in the administration of justice also affects the daily regimes of judicial officers, lawyers and corrections and courtroom staff. These are the people who interact with AVL on an ongoing basis, whereas prisoners’ usage is currently likely to be more sporadic.

# Design Research

---

## Introduction

---

Considerable design research was conducted to inform the development of the design in this project. This included stakeholder/user workshops, site visits and an iterative design development process. The general methodologies and specific studies undertaken are outlined in the previous Methodology section. In this section is a brief summary of information collected through observations and discussions about the design of physical spaces and technology systems associated with AVL. The information presented covers both the custody and court aspects of the system. We also provide separate summaries for the adult and juvenile context as there were substantial differences. As stated in the previous section some of the specific data and findings of the design are not reported because of the limitations of the ethics clearances.



# Design Research - Adult Jurisdiction

## Custodial Context

### AVL Support Facility

Each Correctional Centre we visited had an AVL support facility. This is a dedicated facility to support the different functions associated with defendants attending court via AVL. It commonly includes a staff office, a number of court-custody AVL studios and legal AVL studios, a waiting or holding area, and associated circulation spaces.

The AVL support facilities we visited varied substantially in their design. Each was an example of an AVL facility being retrofitted into an existing space. In the case of Dillwynia this involved the AVL studios being placed within the Visits Centre, using existing staff office spaces and waiting areas. In the two male prisons, old buildings were repurposed to create an AVL facility. In these facilities holding areas were best described as cages located outside and under a shed structure.

General concerns or issues with the design of the AVL support facility:

- lack of mechanical heating or cooling in the waiting/holding areas in the male prisons
- lack of space in the holding areas with as many as 20 inmates being held in 25 sqm cages creating tension and stress for staff and defendants



Long Bay holding yard

- toilet facilities within holding areas degrading with no opportunity for privacy when the facility is busy
- difficulty providing defendants the opportunity for private telephone conversations with their legal representatives in some facilities
- lack of facilities to occupy time productively including inmate phones
- no indication in the design that the AVL support facility was serving a function for the judicial courts

Opportunities and suggestions for improvement included:

- requests for larger, flexible waiting spaces that are purpose designed to meet the needs of defendants and staff. This needs to include reasonable consideration of environmental quality, noise and personal space
- two facilities had an open, break-out area adjacent to the holding areas where defendants could go when talking on the phones to their lawyers. This appeared to work well and enabled greater flexibility
- installation of inmate prison phones for calling approved numbers
- better access and presentation of information

### AVL Studios

Each AVL support facility included between 2 and 4 AVL court studios, and two legal studios. While there were variations in the dimensions and fit-out of



Signage at Long Bay

the AVL court studios between Correctional Centres, they had a broadly similar aesthetic as shown in the images.

General concerns or issues with the design of the AVL court studios:

- where foam acoustic panelling was installed it was often picked out and unsightly
- few design references indicating that the studio represented part of a judicial court system
- generally, the look and feel of the court studio reflected that of the surrounding corrections environment
- the door and viewing window were often awkwardly within the view of the camera
- no specialist lighting was used – standard office florescent fixtures present in most studios
- no consistency in the spatial and ergonomic dimensions (distance from screen, size of room etc.)

Opportunities and suggestions for improvement included:

- use of fabric covered acoustic panelling that is more durable and formal in appearance

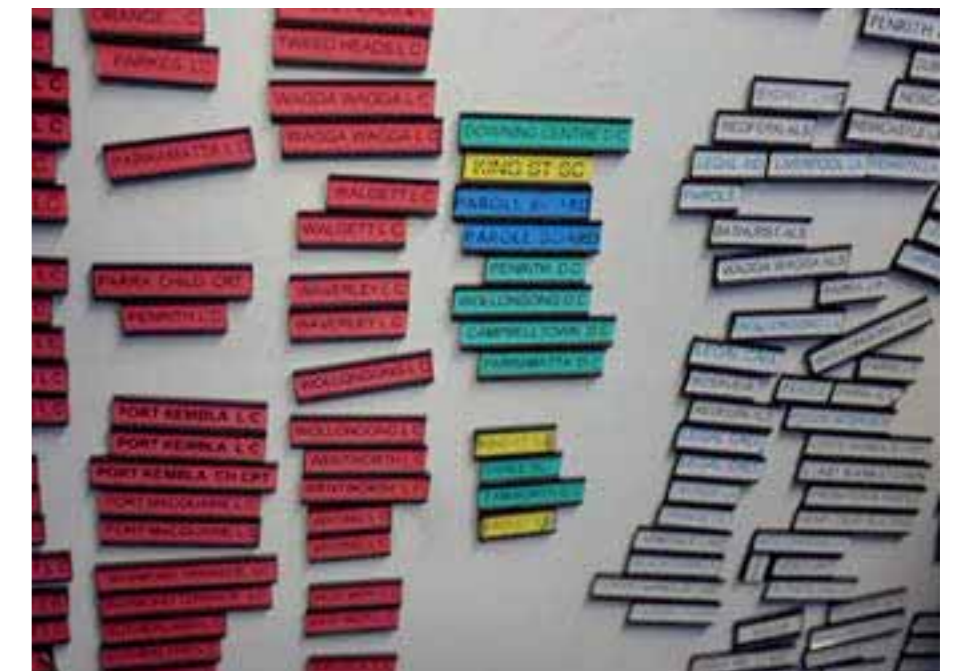

Bathurst CC scheduling process

# Design Research - Adult Jurisdiction

- introduce some of the look and feel of the court into the studio fit-out
- consideration of windows to provide natural light, particularly if there is the possibility defendants could be in the studio for extended periods

## Technology Set-Up

The AVL display screens and camera were housed in a large cabinet that varied in design between facilities. All had a Lexan front protecting the equipment. While the types and size of monitors also varied, the typical screen set-up was two separate LCD computer screens. The left side display was sometimes a larger 28 inch screen and displayed the bench and bar in split screen. The right hand display (often 24 inch) was primarily for showing evidence or private discussions with legal representative during the court proceedings. The camera was located below and in-between the two screens, or sometimes above the main left display on a bracket. The speakers and microphone varied but were most often mounted on the front face of the cabinet below the screens.

General concerns or issues with the technology set-up:

- distracting reflections from Lexan covering the display screen
- camera position and zoom, tilt and pan varied widely so defendant were sometimes off centre and awkwardly positioned

- the split screen on a 28 inch display resulted in quite small pictures of the judicial officer and legal representatives
- the white background graphic on the screen drew attention away from the images of the court
- connection to the court was often abrupt with little warning
- no specific system or procedure for defendants to alert staff or the court of a technical problem
- AVL custodial staff do not have the capacity to directly monitor the court-custody AVL feed to detect problems. Only have a view from an additional CCTV camera

Opportunities and suggestions for improvement included:

- develop templates or a testing procedure to ensure camera set-up properly frames defendant
- consider the introduction of a Virtual Meeting Room (VMR) system to assist in managing transitions into the court
- consider introducing a modern system which can utilise a single large screen rather than two small screens
- review AVL studio set-up against the ergonomic and technical recommendations
- enable AVL staff to monitor the court feed directly so they can identify issues. Consider 'smart monitoring systems' if available

## Court Context

Most NSW courts are equipped with audio-visual facilities that are used for AVL appearances by defendant from custody, AVL appearances by witnesses and for displaying evidence to the court. Typically, the AVL system set-up includes two large LCD displays, one positioned on either side wall of the court between the bench and bar. The height of the displays vary, though in most courts visited the bottom of the display was at least 2 meters from the ground and as high as 4 meters in some courts. Sometimes the judicial officer also had a small 24-28 inch personal display on the bench.

The AVL court system typically includes at least two cameras. One camera is to capture the view of the bench and judicial officer, and the other is to capture the bar, the prosecutor and the legal representative for the defendant. Both cameras are generally located with one of the large display screens. It varies between court whether they are above, below or on the side of the screen. AVL audio from the custody studio typically is projected through the courts general audio system speakers.

General concerns or issues relating to court-custody AVL:

- large variations in court layout impacts on establishing standard AVL set-up (positioning of dock, bar, witness stand windows, etc.)



Dillwynia AVL studio



AVL cabinetry at Long Bay



Industrial Relations Court (IRC) courtroom 2.1

# Design Research - Adult Jurisdiction

---

- heritage value impacting on the ability to make modifications
- impact of AVL set-up on existing court hierarchy, processes and practices
- high location of the AVL screens creating an artificial defendants view and impacting on natural behaviour/ gestures of judicial officers and legal representatives (looking up and across to see defendant)
- camera position impact on vulnerable witness views of the court and the defendant

Opportunities and suggestions for improvement included:

- integrating AVL fixtures within cabinetry consistent with court aesthetic
- lowering AVL screens so views and gestures more consistent with actual court
- co-location of speakers with AVL screen to enable a directional quality to defendant's speech
- an additional camera that provides defendant a wide angle, contextual view of the court



Second display in IRC courtroom 2.1 (without cameras)

# Design Research - Juvenile Jurisdiction

## Custodial Context

### AVL Support Facility

In this project Cobham JJC and their AVL facility was sole focus in the juvenile jurisdiction. This focus extended to the development concept designs for an alternative AVL facility at Cobham. This summary thus relates to Cobham AVL facility and the concepts design later presented.

The current Cobham AVL facility includes a small staff office, three court AVL studios, a legal AVL studio, four holding cells and circulation space. It is located within the main administration building and was suggested by staff to sit awkwardly in this location.

The location is some distance from the residential and education parts of the Centre leading to long periods of waiting for the young people in the holding cells, and poor time management between court processes and distances to retrieve young people from within the centre.

General concerns or issues with the design of the AVL support facility:

- small disorientating space with low ceilings and no natural light
- the waiting spaces for young people are small 3 sqm cells typically found in police stations. Seating is a metal bench with very small TV screen awkwardly positioned behind Lexan



Cobham AVL circulation space

- staff office does not provide amenity for the whole staff team nor lunch or meeting facilities
- significant distances between facility and where young people are located during the day
- lack of break out spaces where young people can be occupied while waiting and where more relaxed conversation can occur
- there is no indication the facility has a judicial function

Opportunities and suggestions for improvement included:

- locate the facility closer to where young people are during the day
- more flexible layout with break out and outdoor areas
- introduce natural light and provide a staff office with appropriate amenity for the team
- communicate the court function of the facility

### AVL Studios

General concerns or issues with the design of the AVL court studios:

- the red, steel AVL cabinetry is large, cumbersome and distracts from viewing the screens
- while the studios are large, the positioning of the AVL cabinetry off the back wall is awkward and is not an efficient use of space



Cobham JJC holding cell

- seats without backrests or padding
- little indication the space has a judicial function
- in one studio the support staff seating positions resulted in them being in view of the camera
- distracting reflections from Lexan covering the display screen
- camera position and zoom, tilt and pan varied widely so defendant were sometimes off centre and awkwardly positioned
- the split screen on a 28inch display resulted in quite small pictures of the judicial officer and legal representatives
- the white background graphic on the screen drew attention away from the images of the court

Opportunities and suggestions for improvement included:

- integrating the AVL cabinetry into the back wall using an aesthetic consistent with its court function
- more formal seating with backrest

### Technology Set-Up

The technology set-up in juvenile facilities was fundamentally the same as in the adult jurisdiction. It is typically installed and maintained by the same Justice department staff. As such those concerns and suggestion are similar.



Cobham AVL court studio



# Design Research - Juvenile Jurisdiction

---

General concerns or issues with the technology set-up

- distracting reflections from Lexan covering the display screen
- camera position and zoom, tilt and pan varied widely so defendant were sometimes off centre and awkwardly positioned
- the split screen on a 28 inch display resulted in quite small pictures of the judicial officer and legal representatives
- the white background graphic on the screen drew attention away from the images of the court

Opportunities and suggestions for improvement included:

- develop templates or a testing procedure to ensure camera set-up properly frames defendant
- consider the introduction of a Virtual Meeting Room (VMR) system to assist in managing transitions into the court
- consider introducing a modern system which can utilise a single large screen rather than two small screens
- review AVL studio set-up against the ergonomic and technical recommendations

## Children's Court Context

---

The Children's Court is a specialist court to deal with criminal cases, applications for apprehended violence orders, applications for compulsory schooling orders and cases involving the care and protection of children. Many local and district courts where adults appear will also operate as a children's court at specific times. As such most of the issues and suggestions that were mentioned for the adult jurisdiction apply to the juvenile jurisdiction. We will not repeat them again here. If anything, these concerns about the design and technology in these courts have more weight when the defendant is a young person due to considerations in the Children (Criminal Proceedings) Act 1987.

There are a number of Children's Court facilities in NSW where only matters involving children are heard. This includes Parramatta Children's court, Newcastle Children's court and the new Surry Hills children court. Photographs and renders of the Children's Court found online indicate a similar practice of locating AVL screens and camera's high on the wall adjacent to the bench. As such the following concerns are likely to also apply to these courts:

- high location of the AVL screens creating an artificial defendants view and impacting on natural behaviour/ gestures of judicial officers and legal representatives (looking up and across to see defendant)
- impact of AVL set-up on existing court hierarchy, processes and practices



Torn soundproofing in a Cobham AVL studio



Newcastle Children's Court

# Framing

*Planning and Finding Your Way - Navigating the AVL Court Process*

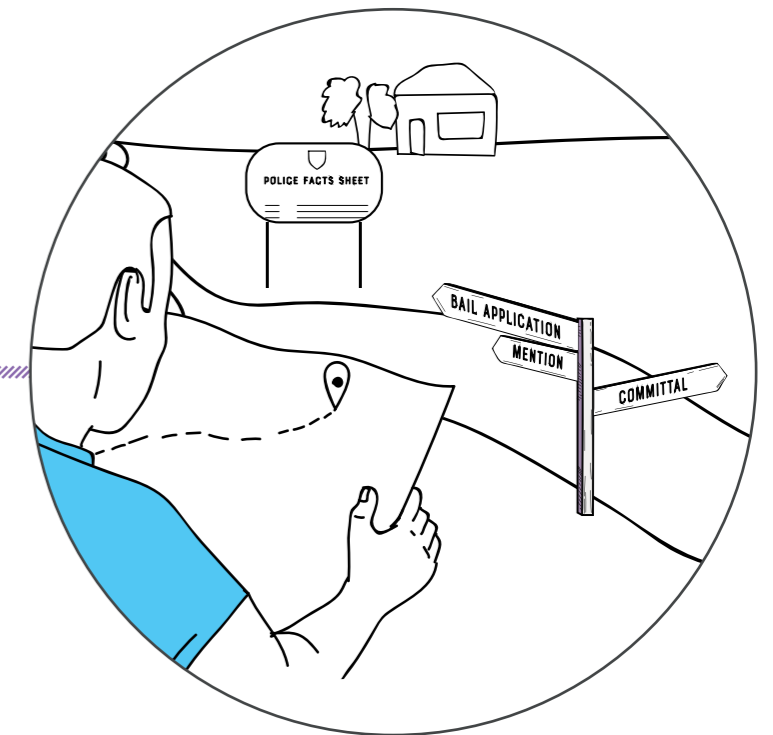

# Framing: Planning and Finding Your Way

A person's first interaction with court and legal processes can be confounding. It's not always clear "where you are" and what the path ahead looks like. The use of AVL adds a layer of ambiguity to already complex processes. This is how the court and AVL experience was described to us by stakeholders, and what we observed in the correctional centres and courts that we visited.

Court appearances via AVL have increased and continue to do so at a dramatic rate. Its use has required changes in the associated court and legal processes and extra amenity within correctional facilities. To date, the introduction of technology in these contexts has often been managed in an improvised fashion – processes and systems have been adjusted to respond to and catch up with the technology. This approach is understandable, as the stakeholders involved operate in environments with restricted time, space and resources. Such an approach, however, does not always lead to clarity for participants. AVL technology is undoubtedly changing aspects of the justice system and people's experiences of it. It is both highlighting longstanding ambiguities in the court system and raising new challenges, such as the meaning of being visible, present, represented or participating in court proceedings. Our findings and the research (McKay, 2017) suggest many AVL participants feel "lost and confused" in the current process. This is impacting on judicial officers, legal representatives and defendants' capacity to create and maintain a court process that is procedurally just.

With this change comes opportunity as well as challenges. The key opportunity driving our work in this project can be summarised with the question: how could we re-evaluate the AVL court experience as a whole? We suggest that it is helpful to consider parallel approaches to navigation to identify potential answers. 'WAYFINDING' is one such approach, and offers a productive framework through which to rethink and re-design the navigation of the AVL + justice system. Wayfinding is an area of design that incorporates physical, communication and system design, with the purpose of leading people from one place to another. There are eight principles of wayfinding that form an overview of how to effectively guide people through a place. These principles are:

1. **Create an identity at each location, different from all others**
2. **Use landmarks to provide orientation cues and memorable locations**
3. **Create well-structured paths**
4. **Create regions of differing character**
5. **Don't give the user too many choices in navigation**
6. **Give navigators a vista or map**
7. **Provide signs at decision points to help wayfinding decisions**
8. **Use sight lines to show what's ahead**

A unifying feature of all of these principles is the objective to optimise clarity and visibility for the navigator. This is a key component in helping people to find their way, whether that be through a physical, virtual or procedural landscape. Increasing clarity and visibility at various touch points along the AVL and court journey could significantly reduce the feeling of being "lost and confused".

In spatial wayfinding, it is acknowledged that people have different styles of navigating. As Per Mollerup writes in 'Wayshowing: A Guide to Environmental Signage Principles and Practices': *"The choice between planning and finding is a question of personal preference. Some travellers prefer safety. Others seem to say 'I don't plan, I find'"*. 'Planners' prefer to have a map and other information about their destination before they embark on their journey, so that they know what to expect when they get there. 'Finders' prefer to be informed about the journey when they are already on it. There is a clear overlap here with what we have found in this project. Some participants were eager to learn about the court and legal process, so that they could feel "prepared" for what was next. Others were not interested in learning any more about the process than was required. The eight wayfinding principles listed, and the design solutions presented in this report, cater for both navigational styles.

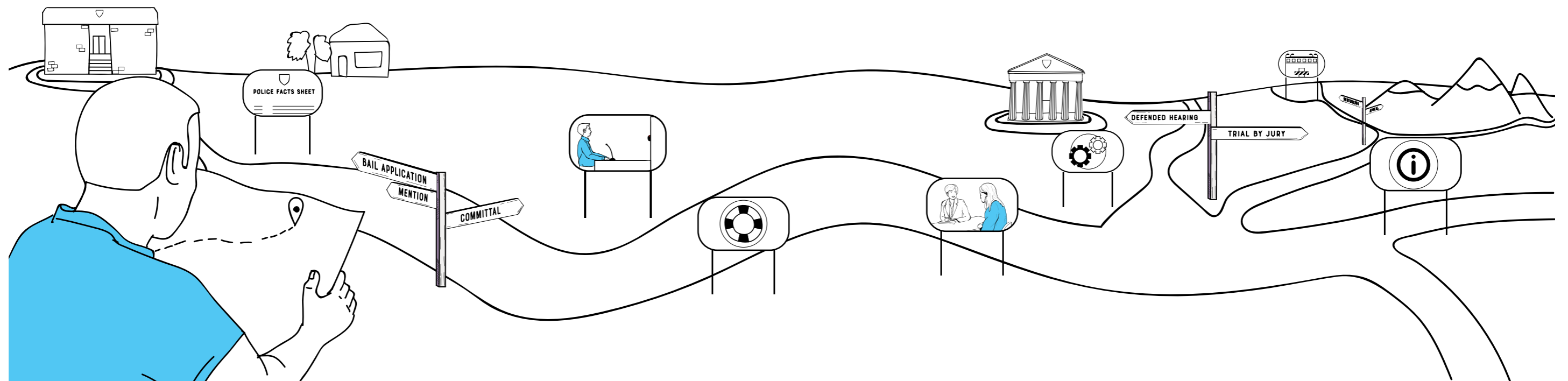

# Framing: Finding Your Way

We describe each of the eight principles and articulate how each informs and provides new insights for the design of an AVL system that can be better understood and navigated. Its utility spans across the architectural, interior, visual communication and interaction design aspects of the project.

## 1: Create a unique identity at each location

### What's it about?

This principle relates to position and orientation. Every location should have a unique identity (i.e. it is distinguishable from others), allowing the navigator to locate him or herself in a specific place, within a broader context. Physical and virtual places should function as 'landmarks', becoming recognisable points of reference.

### What does this mean for court-custody AVL?

The purpose and function of each location in the court-custody AVL landscape need to be clearly defined, helping the defendant to physically and mentally "position" him or herself for their court appearance. In the custodial environment, this means that the design of the AVL area – including the holding cell, the AVL studio and the circulation space – communicates to the defendant that he or she has transitioned from the correctional centre into a place of law – the "legal house" (see AVL Facility Architecture, from p40). It may only be a few steps between the two 'locations' but is an important distinction to make.

On-screen, the convention of displaying the judicial officer's image at left and lawyers' at right helps the defendant "locate" each of them during an AVL appearance. The separation reflects the separation of purpose and power between the roles within the court. In the physical courtroom, the co-location of the cameras and screens within the defendant podium virtually "places" the defendant in the courtroom. This is similar to the function of the dock.

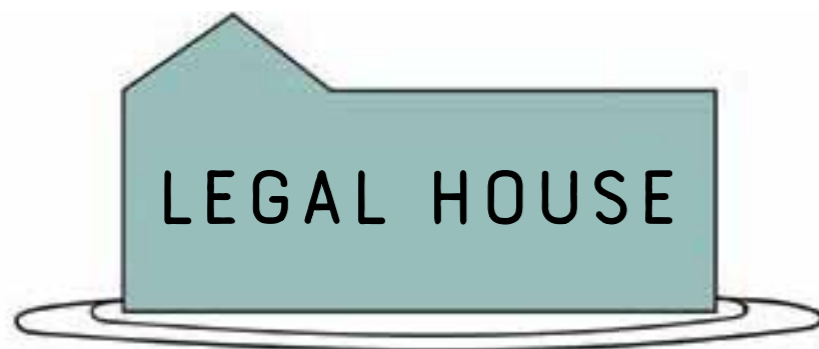

## 2: Use landmarks to provide orientation cues and memorable locations

### What's it about?

Landmarks can be spaces or objects. Landmarks serve two purposes – one is to help to give people their bearings – so that they can know where they are within a space, which way they are facing, and how close or far away something is. The second is to create memorable locations – landmarks help people to remember places (and associated events/actions) and help to create a shared vocabulary when discussing places with others.

### What does this mean for court-custody AVL?

The physical locations – i.e. the holding yard AVL legal and court studios, and the courtroom – are the landmarks in the context of court-custody AVL. The hierarchy of the court is embedded in the physical design of the courtroom and elements of this (e.g. the bench, the bar table, etc) act as 'landmarks'. In the context of this project, the display of the defendant's image and voice within a three-dimensional podium – converted from a flat screen on the wall – creates another important "landmark".

On the custodial side, the design of the AVL studio incorporates symbolic landmarks to reference to the hierarchy of the court. This is achieved through the use of quality materials and finishing, as well as the height of the equipment cabinet and display of the coat of arms.



## 3: Create well-structured paths

### What's it about?

Paths serve to guide a person through a space, from one point to another. A person travelling on a well-structured path knows where the beginning, middle and end of it is, knows which direction they are headed, and has a sense of their progress along that path (i.e. what has been done, how much more remains). A path may be structured by landmarks (described above).

### What does this mean for court-custody AVL?

In the correctional centre, signage along the route from the wings to the AVL area helps to structure the path from 'correctional centre' to a 'place of law', and from 'everyday activity' to 'an important event'. The orientation materials – particularly Your AVL Notebook and the AVL Guide Cards – also help the defendant to understand the path that they are on, and the different route options that are available to them.

Within the AVL area, the design incorporates a 'path' from the holding area, to a circulation area, to the AVL studio. The AVL studio has a clear structure that draws on that of a courtroom, communicating to the defendant that they have 'arrived' in a court space. There is a clear 'destination' for the defendant within the AVL studio, a respectful distance from the screen.

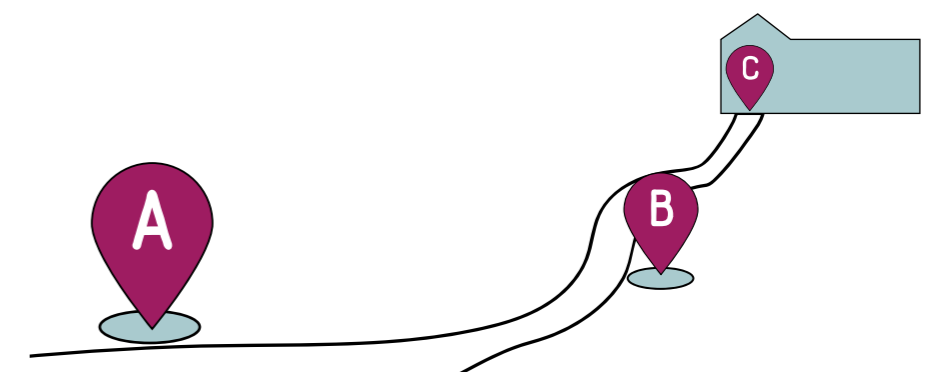

# Framing: Finding Your Way

## 4: Create regions of differing character

### What's it about?

This principle relates to how a space is divided into sections, differentiated by visual attributes, purpose/function or boundaries. The boundaries can be literal or conceptual, but in each sense serve to contain certain elements and exclude others (creating a 'space within' and a 'space outside').

### What does this mean for court-custody AVL?

In the custodial environment, there are clearly demarcated regions in relation to AVL – each wing is a *pre-* and *post-AVL region*. The location of the legal glossary and tip cards here assign the wing with the function of education and/or support (in that this is an area that allows defendants to prepare for, and reflect on, their AVL court appearance).

The AVL area is clearly a *legal region*. This region is itself divided into sub-regions: the holding room/s, a circulation region, legal call studios, AVL studios and the officers' area. The design of the AVL facilities in this project respect and underscore the different functions of each of these regions. This project has also allowed us to consider "virtual regions". In the AVL studio, the pre-appearance video signals a 'transitional' region – it is the 'entrance' to the individual's court appearance. On-screen, the the judicial officer's region is at left the prosecution and defence lawyers' region is at right (possibly with members of the public visible in the background). This separation clearly speaks to the different levels of power held by each person.

In the courtroom, the podium for the screen displaying the defendant's image designates this as his or her region, and clearly communicates where to look when speaking and listening to the defendant. This is comparable to the function of the dock for in-person appearances.

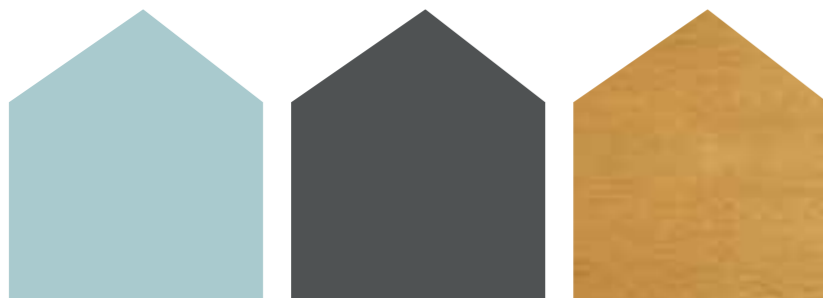

## 5: Don't give too many choices in navigation

### What's it about?

This principle relates to the notion of clearly communicating the choices that a person has (in navigating through a space) through design, and not including unnecessary options that may be confusing. This involves having a holistic picture of which routes are available, and carefully considering how they should be signposted (whether literally or figuratively). The intention is to make decision-making easier by clearly indicating what choices are available and where each one leads.

### What does this mean for court-custody AVL?

The orientation materials provide content to help the defendant make informed choices about the 'journey' that is their court case. The materials are pared back, giving no extraneous information. Where possible, they clearly indicate where multiple options are available to the defendant in different situations, and where there aren't (e.g. in being required to wait in the holding room).

The design of the AVL area and studio also align with the principle. It is clear through structure and placement of pathways and objects where the defendant should be at each stage. There are no unnecessary features in the AVL studio that could distract the defendant from their court appearance.

In the virtual space, the screening of the pre-appearance video clearly indicates when the defendant is commencing his or her own court appearance. The intuitive positioning of screens and cameras in the courtroom helps the defendant in the AVL studio recognise when he or she is being addressed, making it easier to focus on the questions or comments at hand and, if necessary, make decisions. Similarly, this makes it clearer to the judicial officer and lawyers where to look when addressing the defendant.

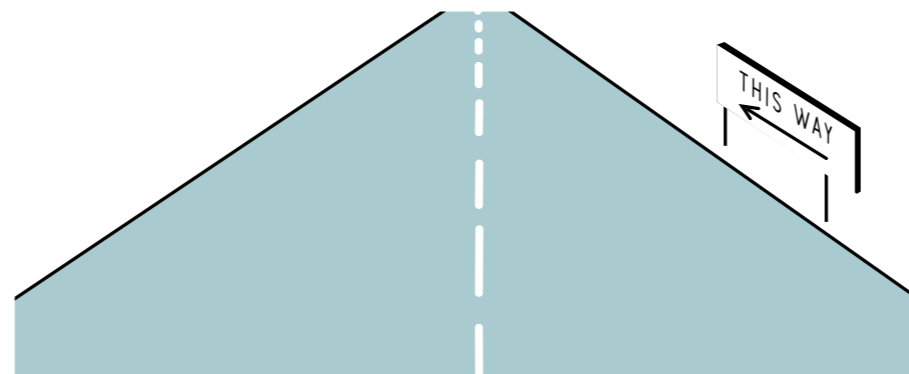

## 6: Give navigators a vista or map

### What's it about?

A map provides oversight (a survey view) of a space. Maps can be particularly useful when it is difficult/impossible to see a space or journey in its entirety from within it. A physical map can "prime" a person to construct his or her own mental or cognitive map. If a person views a map prior to embarking on a journey, that person can feel more prepared for what to expect, and less reliant on in situ signs/route-markers to inform them. A map visualises space and elements in a symbolic way, which can help a person comprehend the relationships that exist between spaces, or pieces of information. In sum, a map can help a person make informed choices about which direction to take.

### What does this mean for court-custody AVL?

The orientation materials perform the "map" function in the context of AVL. The AVL Guide Cards translate information about the AVL, court, legal and detention systems into visualisations and plain language. This provides the user with some oversight of the justice system and his or her position within it. The legal dictionary functions as a linguistic 'key' to the legal process, allowing the user to decode and make sense of information they receive in court and in discussions with legal representatives. The Your AVL Notebook resource functions as the defendant's personal map. It provides some 'mapping' information, but also provides space for the defendant to draw their own map, or at least their own reference points. These reference points could include, for example, salient pieces of information related to their case(s) – e.g. court dates and lawyer contact details.

In the AVL studio, the Pre-Connection Video informs the defendant of what he or she can expect to see and hear during the appearance (e.g. how the judicial officer and the lawyers will be shown), and in this way is similar to a map.

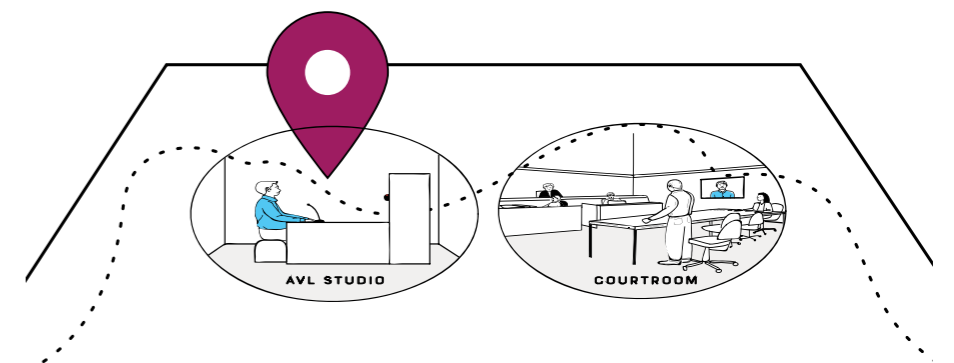

# Framing: Finding Your Way

## 7: Provide signs at decision points

### What's it about?

In navigation, a person will often have a goal that he or she has decided they want or need to achieve, and know the overall path that needs to be taken. However, this person may encounter several smaller junctions – or wayfinding decisions – along this path, at which he/she needs to make a decision (e.g. to continue in a particular direction or to change course). Signage or notifications are helpful at these junctions, as they can make clear where a path is headed and prompt a decision to be made.

### What does this mean for court-custody AVL?

In the correctional centre, it is impossible to create one-size-fits-all signage related to decisions in what to do legally, given the many variables in the court/legal process. However, in the context of navigating the physical areas of the AVL process, the introduction of signage to areas in the correctional centre (i.e. on the path between wing and AVL area, holding room(s) and AVL Studio) makes routes and destinations clearer to the defendant.

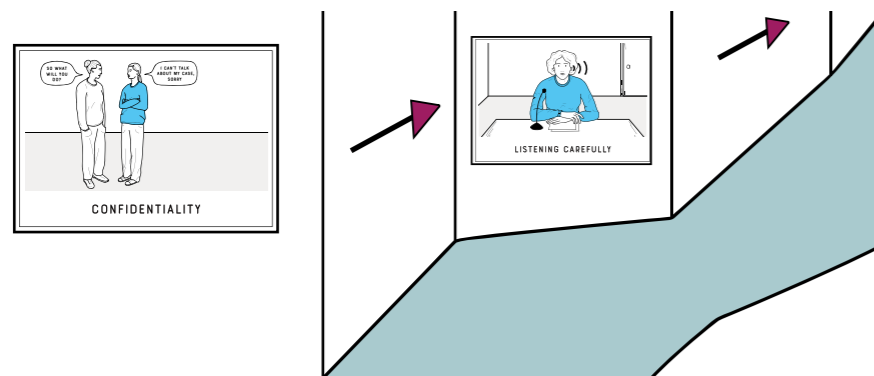

## 8: Use sight lines to show what's ahead

### What's it about?

A sight line allows a person to see from one end of a path to the other, showing the destination that lies at the end of it. This is different to a sign, for example, which tells a person that a destination is in a certain direction (meaning the person has to trust the sign as opposed to seeing for him/herself where a path leads). Clear sight lines (and the destinations or landmarks at the end of it) can create “visual magnets” that can lead a person from one place to another.

### What does this mean for court-custody AVL?

Within the scope of this project, there are limited opportunities to create clear “sight lines” for defendants outside of the AVL area itself, given the ‘closed’ nature of the custodial environment. Within the AVL area, however, the circulation space allow the defendant clear sight lines from the holding room to the AVL studio. This allows the defendant to prepare for the “destination” of the AVL studio, and their court appearance.

In the virtual space, there are again limited opportunities for creating clear “virtual” sight lines, given the complicated nature of the existing technical systems. However, the defendant podium in the courtroom provides an equivalent to ‘sight lines’. This design feature makes it clear, for both the custodial and the court side, who is speaking and whom they are speaking to. From the defendant’s perspective, having visibility of facial expressions of those in the courtroom side makes it easier to follow the discussion and to know when he or she is being addressed. From the courtroom’s perspective, the podium signifies that the defendant is “present” in the courtroom and makes it clear where to look to address him or her. These “clear sight lines” can alleviate some of the confusion that is often experienced on both sides due to being in separate physical places.

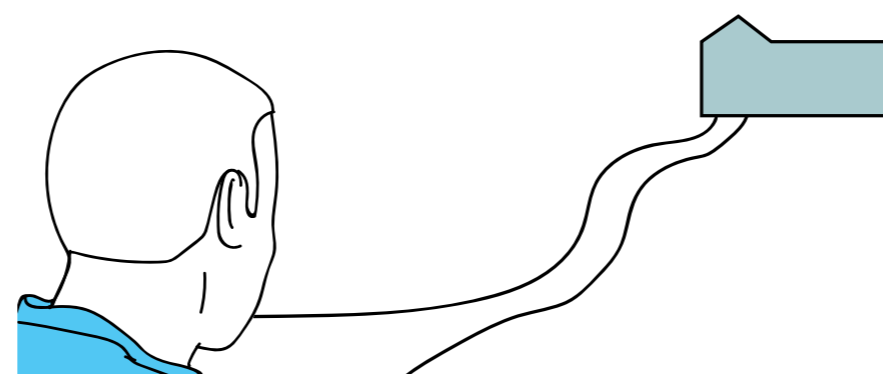

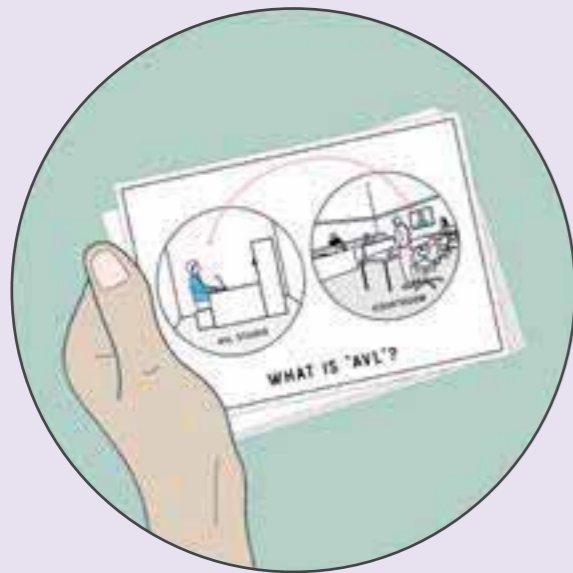

Orientation Resources



AVL Studio Design



AVL Facility Architecture



Court Interface Design

---

## DESIGN

# Orientation Resources

---

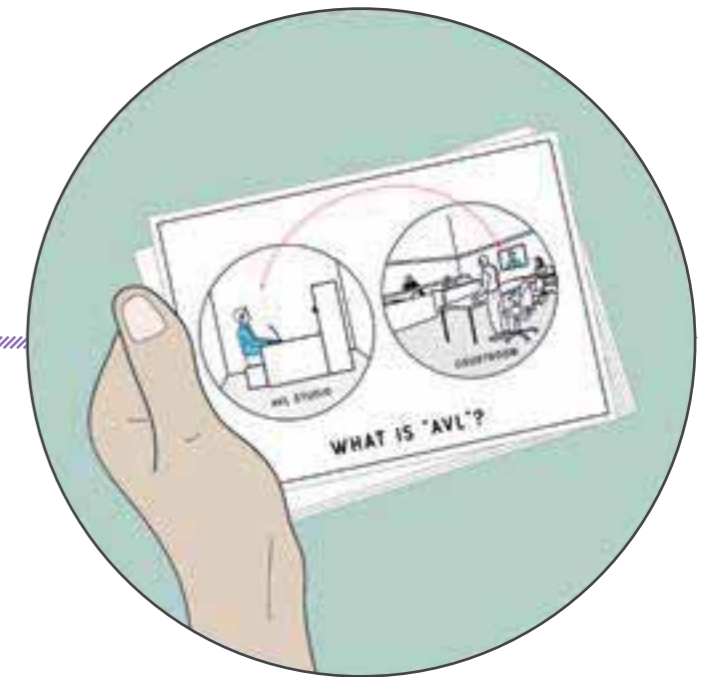



# Introduction

---

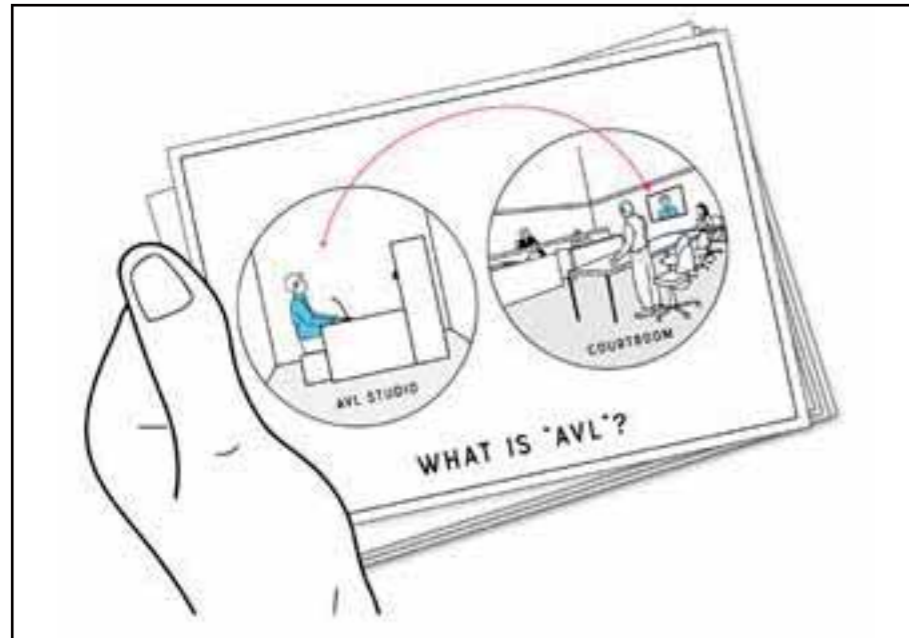

AVL Guide Cards

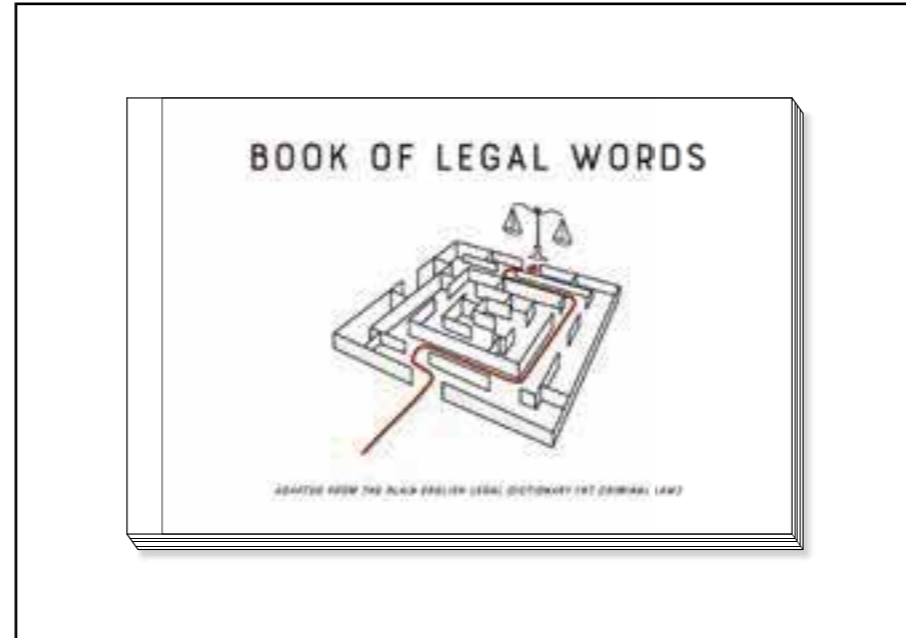

Book of Legal Words

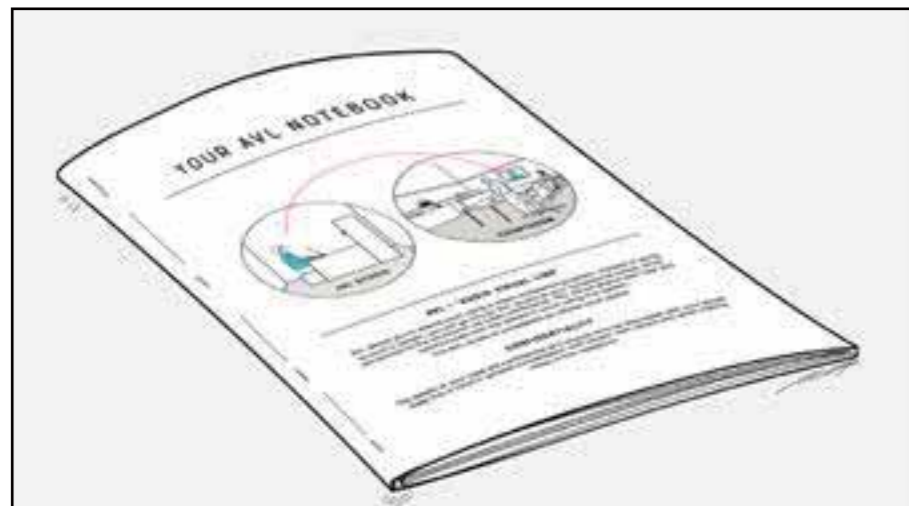

Your AVL Notebook



Pre-Connection Video

## Overview and Intentions

---

In the project we have created a range of orientation resources that seek to enable participants to plan and find their way through the AVL process. Defendants are currently faced with a complex situation containing many unknowns - these orientation resources work together as a body of support materials to provide guidance on the process, terminology, perception and behaviour amongst other things. Some resources target specific stages of the AVL process using delivery modes appropriate to that situation. The resources design include the four shown to the left (AVL Guide Cards, Book of Legal Words, Your AVL Notebook, Pre-Connection Video) as well as three other designs to aid with sense-making. Together these resources aim to support the provision of a fair and just AVL experience and to enable defendants to be engaged through judicial processes.

# AVL Guide Cards

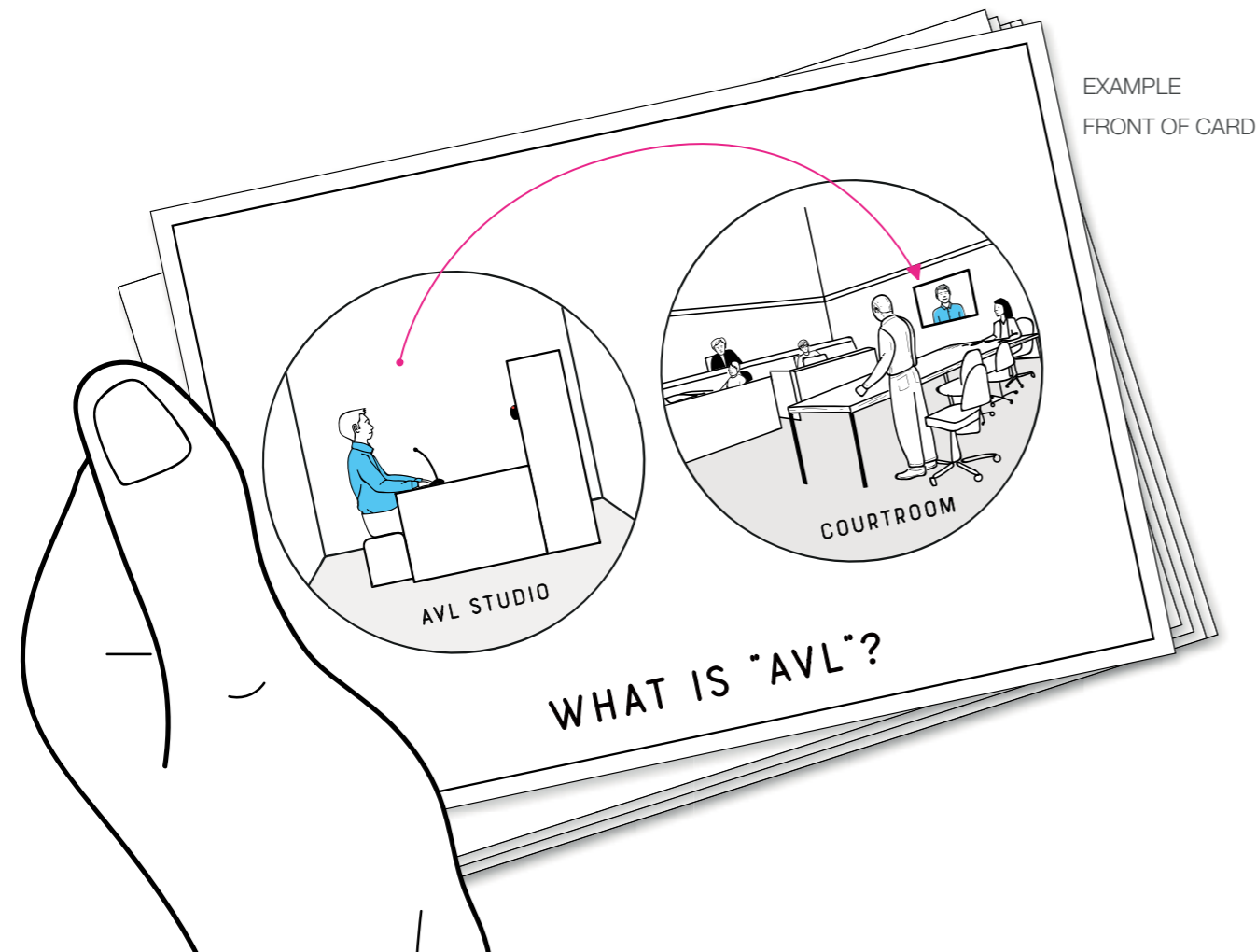

## Intentions

Through the medium of a set of over 40 cards, the AVL Guide Cards transform an otherwise overwhelming amount of information into manageable pieces, and in a simple, aesthetic and adaptable format.

The cards cover five general categories of information:

- the basics of AVL and court;
- court/legal procedures;
- preparing for AVL and court;
- what occurs during an AVL appearance;
- and finding support.

The intention of this resource is to provide clarity for people in custody about AVL, legal and court processes. The cards provide answers to common questions, helping to ease potential anxiety and manage expectations. The

cards can help to empower the user with knowledge and provide them the ability to position themselves within the journey of their AVL court processes.

It is proposed that the cards are made available in communal areas in correctional centres – in each wing, library and in each AVL holding room/area. We also recommend that AVL officers have a copy of the Basic AVL Guide available in their office as a helpful resource for occasions they are asked questions by inmates.

## Design Attributes

The product was designed as a set of cards, as opposed to a bound book, to facilitate and encourage browsing. While the information fits into general categories, it does not need to be read in a specific order – users can dip in and out of the cards as they please. This loose structure of the card set,

combined with their material sturdiness, makes it a tactile object, different to a book. This means that the cards can serve a dual purpose, giving the user both helpful information, and something to occupy their hands with. This can be particularly useful when users have an extended period of time without much to do – for example, in the holding room/area on the day of an AVL appearance.

The content of each card is 'manageable' in that the amount of information is limited so as not to be overwhelming. The language used aims to be as simple as possible, endeavouring to explain (at times complex) information in plain language. It is envisioned that the cards are translated into the most common languages, other than English, spoken by people in custody.

The illustrations support the text and, where possible, convey the same information visually. If the text is indecipherable (e.g. for a person with limited literacy skills), the illustrations can otherwise act as a prompt to ask for assistance.

# AVL Guide Cards

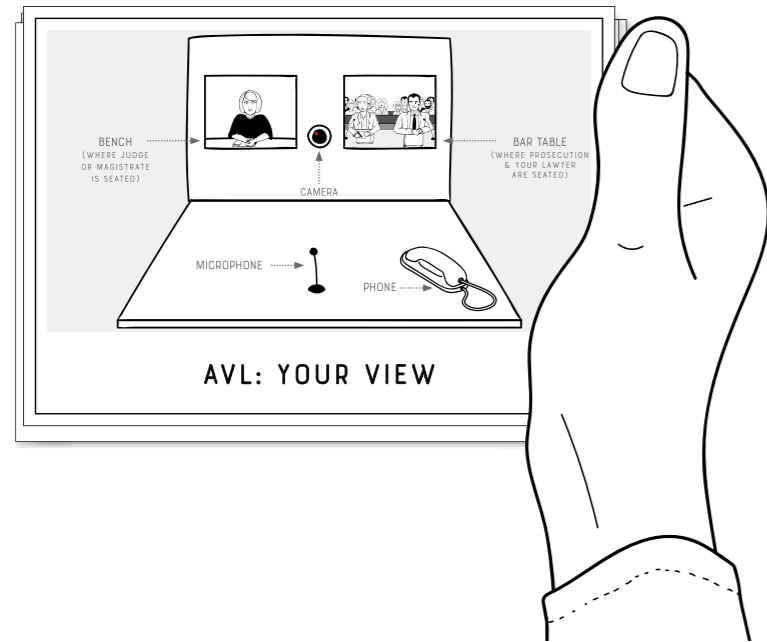

<p><b>PERSONAL APPEARANCE &amp; ETIQUETTE IN COURT</b></p>	<p><b>PERSONAL APPEARANCE &amp; ETIQUETTE IN COURT</b></p> <p>When you appear in court via AVL you can be <b>seen and heard</b> by the courtroom, just like attending court in person. So it is good to be aware of how you <b>present yourself</b> and be polite when <b>speaking</b>. If you are asked to speak to the court, address the judge or magistrate as <b>"Your Honour"</b>. These factors can help you to make a <b>good impression</b> and to show that you take this event seriously.</p>
<p><b>LEGAL ADVICE &amp; SERVICES</b></p>	<p><b>LEGAL ADVICE &amp; SERVICES</b></p> <p>• The <b>Prisoners Legal Service (PLS)</b> is a Legal Aid NSW service that provides advice, assistance and representation to people in custody. • <b>LawAccess NSW</b> is a free government service that provides legal information, referrals and, in some cases, legal advice. Call 1300 888 529. • If you want a <b>private lawyer</b> to represent you and/or give you advice, contact the <b>Law Society of NSW</b> on 9926 0300. Costs vary, so make sure you discuss this in your first interview. • If you are Aboriginal or Torres Strait Islander the <b>Aboriginal Legal Service (ALS)</b> can offer legal representation and advice. Call 1800 765 767. <small>*Also see cards: "What is the Prisoners Legal Service?" and "Contacting the Prisoners Legal Service".</small></p>

## Design Attributes (cont.)

- The cards are A6 sized (i.e. 1 quarter of an A4 sheet of paper). One side of the card features a simple illustration that is related to the topic of the card.
- The back of the cards feature a small amount of text explaining one element of the AVL/court process (with a smaller version of the image).
- The physical design of the cards also makes them "manageable" in the literal sense – they can be held in one hand.
- The cards are designed to be printed on a durable plastic, with the intention that they be made available in communal areas and so may need to withstand heavy usage.
- The tone of the illustrations mirrors that of the text – they are accessible and easy to understand, without being condescending.
- A simple ring keeps the cards together.

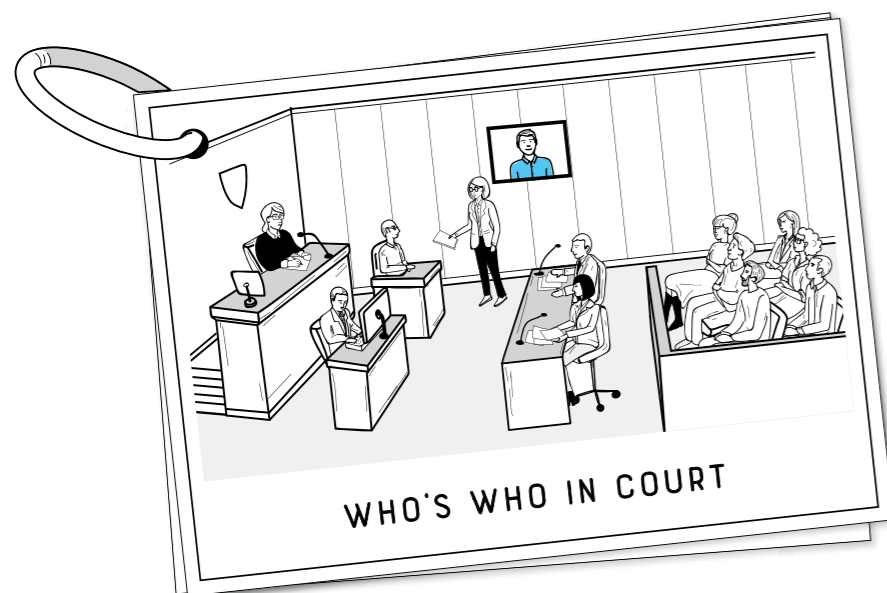

**CONFIDENTIALITY**

## Alternative Uses

There are numerous benefits to the modular and adaptable format of this resource, beyond being user-friendly. Because each card is self-contained, the set can be easily updated – individual cards can be replaced if things change, without having to replace the whole set. The content is also easily adaptable to other formats – such as posters (to be displayed at locations around the correctional centre, namely on the path between the wings and the AVL area) and slideshows (to be shown on the correctional centre's TVs). At the point where iPads or personal tablets are introduced to correctional centres, the cards could be adapted to an interactive format to suit.

# Book of Legal Words

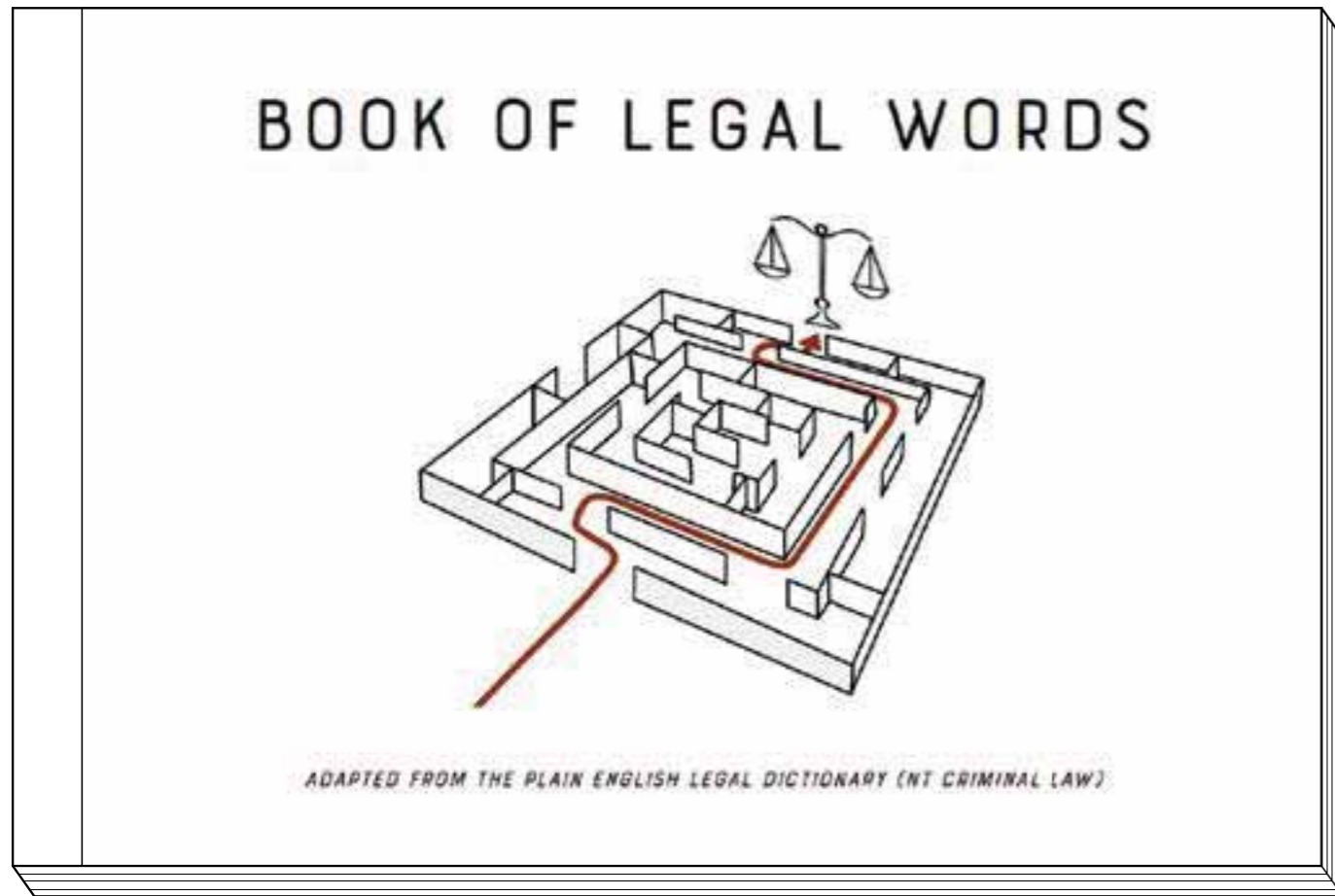

## Introduction

The Book of Legal Words provides defendants and custodial staff with a plain English explanation of 250 commonly used legal words. It is intended as an accessible resource for defendants (and staff) to assist in their understanding of legal words they hear during AVL court proceedings and legal conversations.

The Northern Territory Plain English Legal Dictionary is formally acknowledged as the primary source for many of the definitions. The Northern Territory Plain English Legal Dictionary is an Australian resource informed by comprehensive research and for our purpose by the project Speech Pathologist consultant. To enable its use in the NSW legal context, and in relation to AVL court appearances, a small number of definitions were adjusted, omitted and added.

Significant design research was invested to develop a format, layout and information hierarchy to the Book of Legal Words to make it an approachable, durable and useful resource. This includes using a small book format that is organized alphabetically with one word per page, identifying some underlying topics areas and cross referencing where words elsewhere in the book relate to a definition. Its small size

## Issues & Opportunities

Many legal words are not commonly used in everyday life – they have specific meaning related to the court process. Consultations with defendants and staff in the adult and juvenile contexts indicated people new to the system often did not understand common legal words. This impacts on their ability

to understand the court proceedings or their conversations with legal representatives.

A number of legal word resources currently exist, some specific to NSW, however they are not readily assessable to defendants and staff in custody. They are either online or only found in the prison library that is often difficult to access. Many existing legal word resources also only cover 20 or 30 words, do not use plain English or are in a format that does not facilitate their sustainable use in custody. Stakeholder indicated a need for a specific resource adapted and designed for the AVL custodial in context NSW.

# Book of Legal Words

---

<p>ABC</p> <h2>ACCOMPLICE</h2> <p>An accomplice is a person who helps another person break the law.</p> <p><b>RELATED WORDS:</b> <i>common purpose; accessory</i></p> <p><b>THEME:</b> People</p>	<p>ABC</p> <h2>ACCUSED</h2> <p>In the Supreme Court, the person who police say broke the law is called the accused. In the Local Court, that person is called the defendant.</p> <p><b>RELATED WORDS:</b> <i>Supreme Court; Local Court; defendant</i></p> <p><b>THEME:</b> People</p>
---	--

<p>ABC</p> <h2>ACQUIT</h2> <p>Acquit is when a judge, magistrate or jury decides that a person did not break the law.</p> <p>When a judge, magistrate or jury listens to the evidence in court and does not believe that the defendant broke the law, they will acquit the defendant and set them free from the charge.</p> <p><b>RELATED WORDS:</b> <i>Supreme Court; Local Court; defendant</i></p> <p><b>THEME:</b> Court</p>	<p>ABC</p> <h2>ACT</h2> <p>An Act is a law made by parliament.</p> <p>The Commonwealth Parliament, and the State or Territory parliaments make Acts. Usually each Act is about one area of law, like these: Traffic Act, Misuse of Drugs Act, Property Act.</p> <p><b>RELATED WORDS:</b> <i>legislation; parliament; statute</i></p> <p><b>THEME:</b> Laws</p>
--	--

## Design Attributes

---

The content, format and materiality of the Book of Legal Words is designed to facilitate its use with young people and adults in custody. This includes:

- Approachable small format booklet organized alphabetically with one word per page
- Word definitions in one or two sentences using a bold font to draw the readers' attention
- Examples of the legal word used in context provided below the definition where relevant
- Colour-coded themes aim to create different pathways for users to explore the words, whilst also adding an element of aesthetic court formality
- Self-contained with no legal terms used that cannot be found within the book
- For durability, printed on never-tear paper and thermally bound

## Context of Use

---

The Book of Legal Words is a resource for defendants and staff to enable them to look up information about specific words as well as being read generally to build knowledge, understanding and confidence relating to legal terms and the court process. The Book is intended to be available in custody in a number of locations including:

- The waiting area in each custodial AVL facility
- The staff office in each custodial AVL facility
- The library in each Centre
- The wings or accommodation areas where defendants are predominantly housed.

# Your AVL Notebook

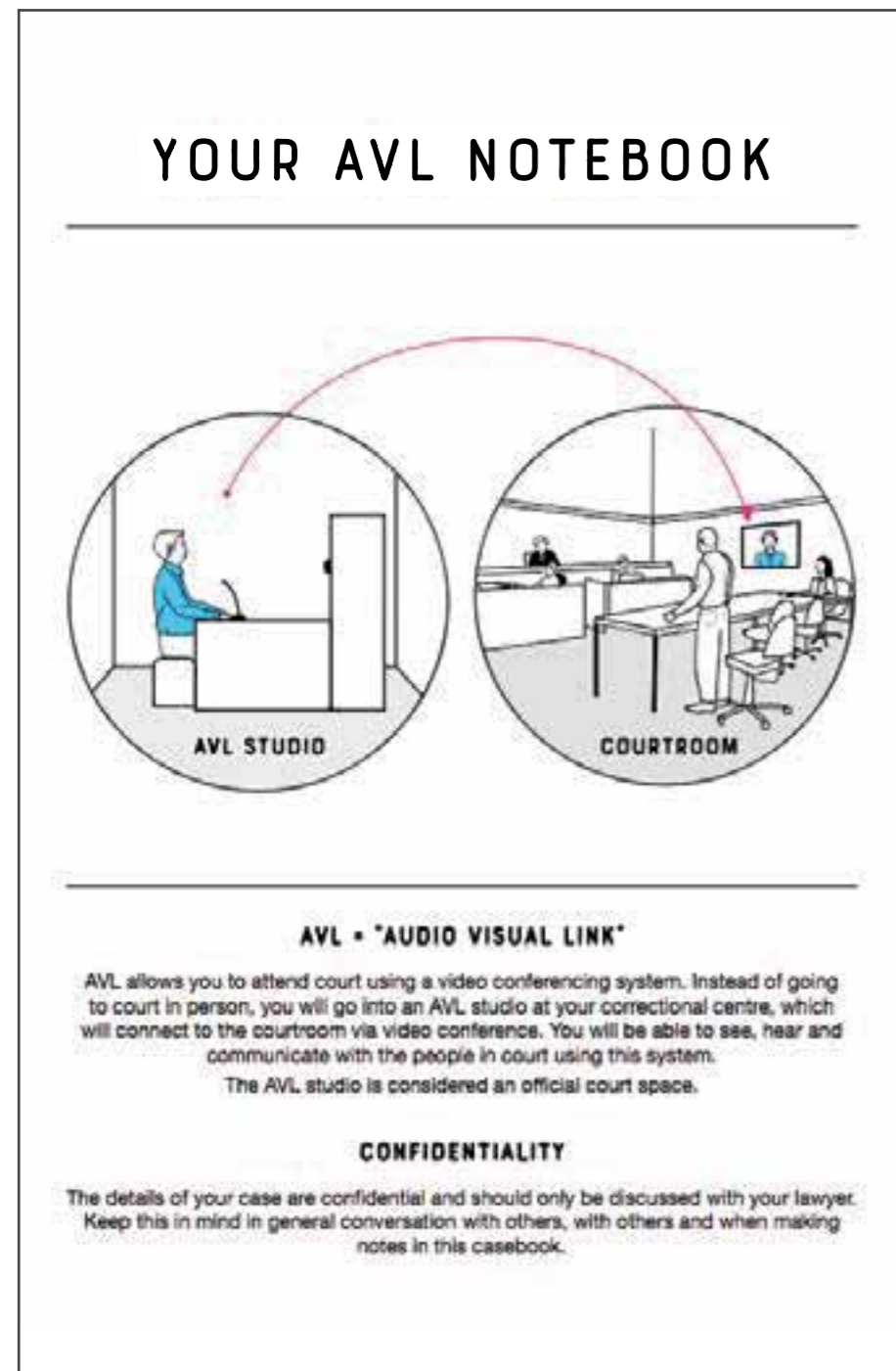

Your AVL Notebook - front cover

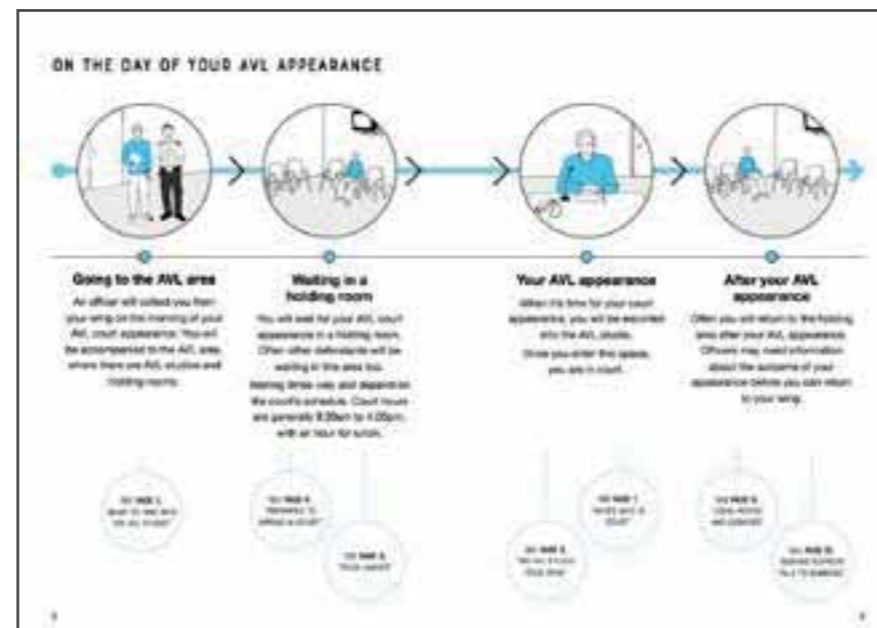

Provision of 'user journey' for defendants



Example spread with space for notes

## Overview

'Your AVL Notebook' is a paper booklet available to each person who is appearing at court via AVL while in custody. It provides some general information about what to expect, how to prepare, legal advice and support, and a calendar to mark down important dates.

Throughout the notebook there are opportunities for defendants to make notes to personalize the information. The AVL Notebook is a defendant's individual resource to inform them of what to expect and assist them in taking responsibility about being prepared for their AVL court appearance.

## Issues & Opportunities

Defendants often stated they were not sure of many details relating to their court case(s). This included court dates, names of legal representatives and people to contact to obtain information or support. We saw many defendants talking with legal representatives asked for paper and a pen to write down notes.

When the idea of a simple notebook was mentioned, both defendants and staff were enthusiastic about the value. For young people who are in custody on remand awaiting to attend court it makes sense that they have a notebook with the relevant information to their court case. Staff in the juvenile justice context indicated young people had few of their own items in custody and would value their own notebook. It was also viewed as a resource that could empower and engage defendants to participate more fully in the court process.

## Design Attributes

The notebook is in a simple A4 folded booklet format. This means it can be easily printed onsite at custodial facilities. The notebook utilizes information developed elsewhere in the project (i.e. guide cards) and compiles it into a more personalized format. This includes spaces throughout for defendants to write notes. Specific adapted versions are designed for adults and young people, male and female.

# Pre-Connection Video

---



## Overview

---

The AVL Pre-connection video is a simple 25-second animated video that a defendant views on the AVL studio screen just before the live connection is made with the court. With modification to the last slide it could also be adapted for playing when the defendant first sits down in the AVL studio. The purpose of the video is to provide defendants with 25 seconds to orientate and prepare themselves before appearing live in court. The video provides a very simple description about what they will see, sets a tone appropriate to the court and gives the defendant an indication when they will appear live in court.

## Issues & Opportunities

---

When appearing in person, a defendant moves through the court waiting or holding cell space prompting them to mentally prepare for the transition into the actual court. When appearing in court via AVL there is fewer cues or processes to prompt this preparation process. Staff and defendants indicated that often the AVL system was live into the court when the defendants walks into the AVL studio, or conversely it becomes live abruptly after a random length of time. This can be disorientating and effect a defendants ability to focus to engage in the proceedings. The pre-connection video seeks to provide these prompts to defendants to assist them in feeling prepared and focused to engage in the court process.

# Pre-Connection Video

---



Part 1: Welcome to the Audio Visual Link studio for your court appearance



Part 2: You are about to appear in court

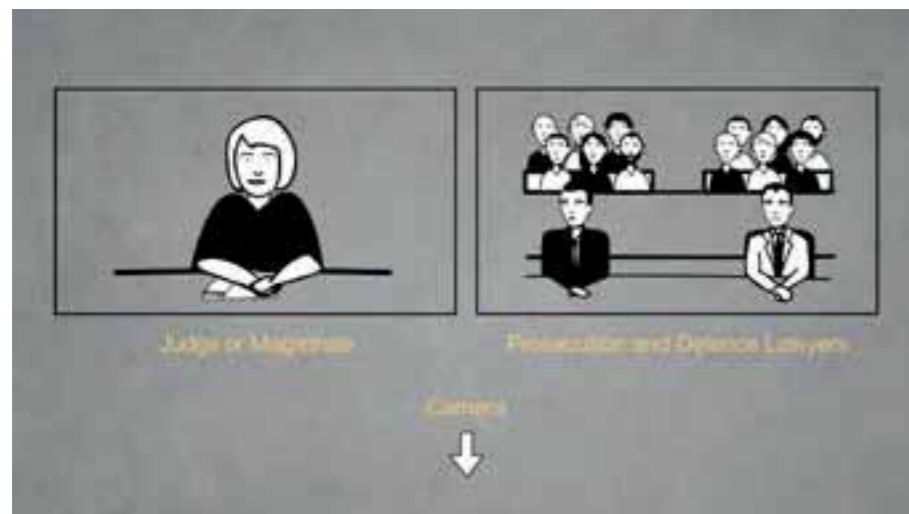

Part 3: The judge or magistrate will be on the left of the screen; the prosecution and defence lawyers will be on the right. When you are speaking, try to look at the camera below



Part 4: You will now enter the court

## Design Attributes

---

The AVL Pre-connection video takes the defendant through a series of 4 narrated and animated slides. The design and aesthetic of the video slides is simple and clear - similar to the other orientation materials. It includes symbols of the court and its formality to orientate the defendant to the importance of the occasion. The progression and narration has a steady, focused pace. The storyboard of the slide sequence with the narrated script is laid out on the adjacent page. The modular design of the video means that video segment can easily be taken away, added or modified for specific purposes.

## Use

---

The AVL Pre-Connection Video is intended as part the AVL court appearance routine. It would be played before every AVL court appearance and be part of the AVL court appearance ritual. Ideally its activation would occur automatically within the current AVL court connection routine and not require additional input from staff.

## Implementation

---

There are a number of possible options for how the pre-connection video could be integrated into current AVL systems and processes. It would ideally be implemented within a Virtual Meeting Room system that would provide a virtual place where transition could be managed in the system.



# Sense-Making Signage

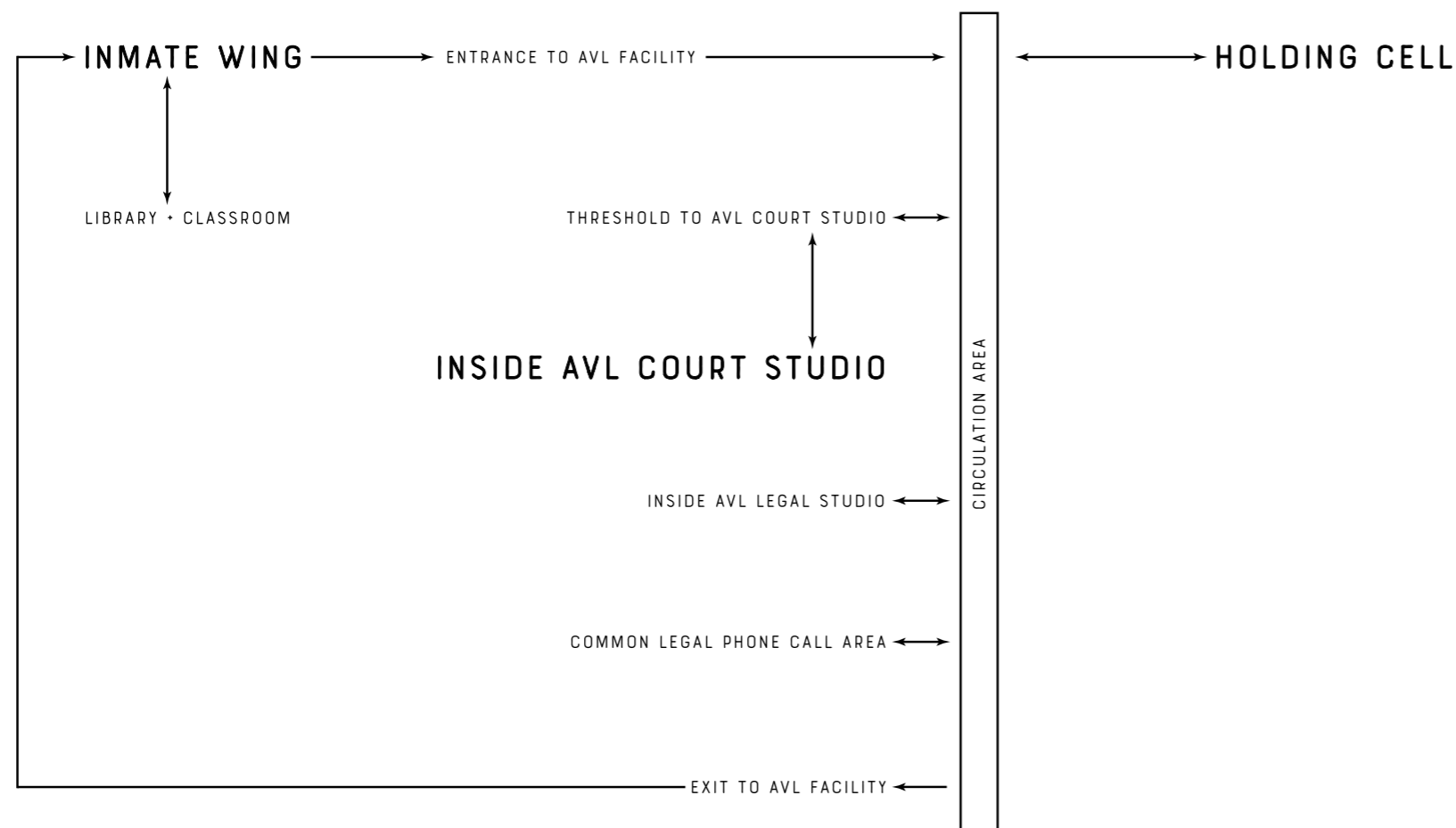

## Overview

There are two primary design solutions that have been developed with the aim of aiding defendant sense-making. Firstly, there is a large banner that depicts the broader defendant journey through court and AVL processes; secondly there are a set of numerous A4 posters providing specific information and support on pertinent aspects of the process. Both the banner and posters seek to address the unknowns that defendants in custody would be facing on the day of a court appearance with the aim of guiding them through the process. The Sense-Making Signage intends to help the defendant situate themselves on the day of an appearance similar to how wayfinding signage can help with direction and navigation.

## Issues & Opportunities

Research found that inmates did not know what to expect on the day of an AVL court appearance nor did they have access to productive ways of spending their waiting time, which sometimes went for the entire day. The designs for signage being presented here strive to provide information on what defendants can expect through the day of their court appearance as well as to act as prompts to help them in preparation. Information given to them through signage could act to stimulate thought and conversation that helps them spend their waiting time constructively. The journey map shown left depicts the potential path of an inmate before, during and after the day of a court appearance. All the locations noted are important junctures at which relevant information in the form of signage could be shown to defendants.

# Sense-Making Signage

## ON THE DAY OF YOUR AVL APPEARANCE

**Going to the AVL area**

An officer will collect you from your wing on the morning of your AVL court appearance. You will be accompanied to the AVL area, where there are AVL studios and holding rooms.

**Waiting in a holding room**

You will wait for your AVL court appearance in a holding room. Often other defendants will be waiting in this area too. Waiting times vary and depend on the court's schedule. Court hours are generally 9.30am to 4.00pm, with an hour for lunch.

**Your AVL appearance**

When it's time for your court appearance, you will be escorted into the AVL studio. Once you enter this space, you are in court.

**After your AVL appearance**

Often you will return to the holding area after your AVL appearance. Officers may need information about the outcome of your appearance before you can return to your wing.

## Design Attributes

### Banner

The banner which is shown left is a large sign that attempts to answer the fundamental concern raised by many defendants while they wait in the holding yard: "why am I here?". It is a tool that aims to let defendants orient themselves on the day of a court appearance and to support them in directing themselves toward productive preparation. Along with an overall visualisation of the AVL journey, the banner aims to address the most important things that defendants might want or need to know when they are waiting in the holding yard. There are three themes running through the banner:

- What to expect?
- How to prepare?
- External support

The actual size of the banner is 1200mm x 500mm (w x h). Its primary context of use is in holding yards, although as a secondary installation it might also be a valuable resource in libraries and classrooms.

### Posters

There are ten posters of which three are shown left; any of the AVL Guide Cards can be adapted as posters and shown where relevant. These A4 posters aim to signal to inmates that they are:

- Preparing for, or in the middle of their court case and
- En route to, or in an official court space

The posters will consist of:

- Information drawn from the AVL Guide Cards, adapted into posters and displayed at locations between the wings and the AVL area
- Posters will be shown in relevant locations, e.g. 'Contact the Prisoners Legal Service' can be shown in AVL legal studios where such matters are already a concern for inmates
- The NSW coat of arms displayed in the holding cell and AVL studio

### TYPES OF COURT APPEARANCES

If you've been refused bail by the court, you will have one or more 'mentions'. In these court appearances, your case will be fitted into the court timetable, or other administrative processes will happen. After mentions, your case may proceed to **committal, sentencing** or to a **hearing or trial** where the court will hear the case and make a determination based on facts.

### SEEKING SUPPORT: TALK TO SOMEONE

**Waiting** for information about your court appearance, or accepting your verdict, can be distressing. It can help to **talk to someone** who can offer **personal support**, such as a **family member** or **friend**. Talk to them from the correctional centre's phones and if possible arrange a face-to-face visit. A **counselor** can also help if you feel worried, depressed, angry or confused. She or he can help you to **clear your mind** and give you **ways to cope** with difficult situations.

### WHAT TO TAKE INTO THE AVL STUDIO

It would be useful to have any **papers relevant to your case** (such as your **pre-sentence report** or **briefs**) in the AVL studio. It would also be useful to have your **AVL Casebook** (or at least some blank paper) and a **pen** to write down notes, important dates, as well as things to ask your lawyer after your AVL appearance. If you have a lawyer, she or he can also give you advice on what information or documents that you should have with you.

### CONTACT THE PRISONERS LEGAL SERVICE

You can contact the Prisoners Legal Service on the **gaoi CADL phone system** as a free call - just press **11# (Legal Aid)** and ask for **PLS**. If you need an appointment with a PLS solicitor, ask your gaoi's wing officer to put your name down in the **Legal Aid Book**. Your **friends and family** can contact the PLS on 02 8688 3888 or fax 02 8688 3895 between 9am and 5pm. You can also **write to them**: Prisoners Legal Service, PO Box 695, Parramatta NSW 2124.

# AVL Studio Design



# Introduction to Concept

---



Video Courtroom 1

The door of the AVL studio has been clad with timber to formalise the entrance. A printed plywood sign with the words 'Video Courtroom' clearly communicates the function of the room, rather than more abstract name such as 'AVL Suite'

## Introduction

---

The proposed AVL studio design has been developed in consultation with Defendants, Magistrates, Solicitors and Operational staff as well as drawing on key recommendations made within a number of recent studies (McKay 2016, Rowden 2013). The design aims to improve the interaction between Magistrates, Solicitors and Defendants with the intentions of offering all parties an open, fair, respectful and engaging experience of justice.

This has been approached in two ways, firstly through technical considerations to enhance comfort, ergonomics and quality of interaction and secondly through a visual language which clearly defines these spaces an extension of the courtroom, providing adequate visual cues to encourage behaviour and interaction that align with going to court.

## Comfort, Ergonomics and Interaction Design

---

Overall comfort has been considered with seat and table height that draw on Ergonomic standards (Pheasant, 1996, pp. 212). Screen size and height, camera position, seating distance from screen, room dimensions and support staff seating position are planned according to detailed user testing carried out by the Designing Out Crime Research Center (Lulham et. al, 2018).

These efforts aim to improve the quality of interaction for all parties involved by ensuring the studio works well technically - Magistrates, Solicitors and Defendants can all see and hear each other clearly, read facial expressions and maintain a suitable level of eye contact achievable with current technology. Hearing loops are to be used where required, especially in juvenile contexts.

## Visual Language

---

The AVL studio has been carefully designed to communicate that these spaces are a physical extension of the courtroom. The materials, spatial planning and design details all reference modern courtroom design. This intends to formalise the experience, communicate the gravitas of going to court, provide an open and fair opportunity to engage in the proceedings, and encourage all parties to adopt the rules, rituals and rights of a courtroom setting. Designing the studio as a court space also provides all parties with a view of each other within a similar visual context, which aims to somewhat lessen the distance and difference that is created with conversations occurring through AVL.

# Design Attributes



## Cues From Court

The design creates a number of court-like thresholds that the defendant needs to pass through, once through the formal door rubber flooring marks an entrance and staff zone. Moving forward a change to carpet requires the defendant to step into their space, like entering the dock. Beyond that, the table has been separated from the screen to create 'The Well' - the space located between the bench and bar table traditionally deemed disrespectful to walk in without a magistrate's permission.

The materials and design details also reference modern courtroom design, such as thick plywood cabinetry, a black table top with a small raised modesty wall, a court emblem and canopy above the judge, and kick plates around the bottom of cabinetry. These features have been used sparingly in the consideration of costing and security requirements, but all contribute to a space which clearly looks and feels like court.



## View of Defendant

---



### Camera View of Defendant

---

In the camera view of the defendant the design has included small details which help to situate the defendant within a court context rather than in the correctional centre. This includes a low modesty panel with printed court emblem, simple timber trim and formalised signage.

The door has also been centered to frame the defendant and the window moved out of frame to hide the view of guards conducting visual checks.



# Design Component Details



1. 9mm Compressed Fiber Cement. Painted Duck Egg Blue

2. 75mm Sontext Acoustic Wall panels:

<http://www.sontext.com.au/fabric-acoustic-panels2/>

Upholstered in Commercial Grey Polyester:

<https://www.warwick.com.au/products/FAD12GLAC>

3. Trim: BlackButt timber (Australian Grown, AFS certified):

<https://pfitzner.com.au/about-us/timber/>

4. 100mm Black Vinyl Skirting:

<http://www.gerflor.com.au/products/professionals/floors/vynaflex-skirting.html>

5. Recycled Rubber flooring. Jazz, Black with 3% mid grey:

<http://a1rubber.com/jazzcomposer/>

6. Feltex Carpet tiles. Equalizer - Fudge:

<https://www.feltex.com/au/commercial/product/equalizer?color=14115&room=718&option=597>

7. White perforated ceiling panels, preferred correctional supplier and assembly to meet security requirements

8. 15mm A/C Plywood canopy mounted flush with ceiling panels

9. 8w Warm Adjustable LED downlight, pointing at emblem:

[www.onlinelighting.com.au/illumina-8w-led-down-light-sku0000261.html](http://www.onlinelighting.com.au/illumina-8w-led-down-light-sku0000261.html)

10. Recessed lighting. PicturePhone Hi-Lite Video conferencing lighting:  
[www.rscbroadband.com/Hi-Lite.asp](http://www.rscbroadband.com/Hi-Lite.asp)

11. Window, 6mm Lexan glazing. Steel frame. Powdercoated brown

12. AVL cabinet. See specs in Appendix

13. Defendant Table. See specs in Appendix

14. Defendant Chair. See specs in Appendix

15. Support people seat. See specs in Appendix

16. Window, 6mm Lexan glazing. Steel frame. Powdercoated brown

17. Signage, see specs in Appendix

18. Door push plate

# AVL Facility Architecture

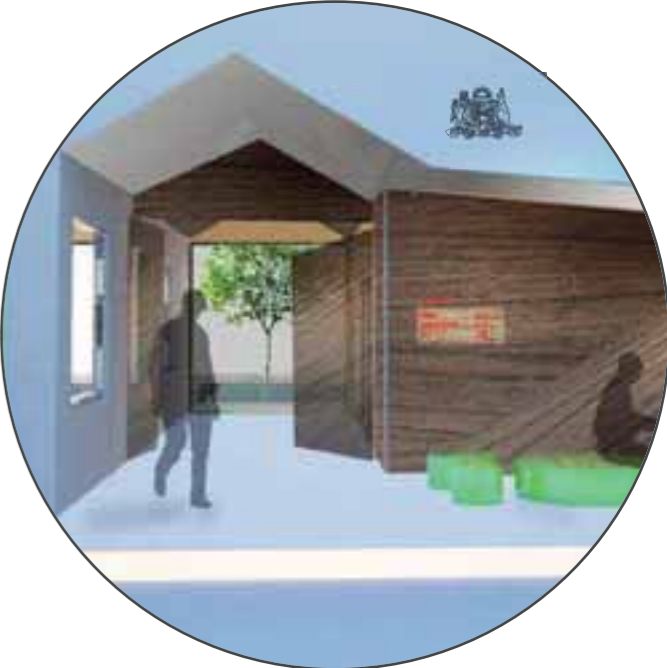



# Concept Background

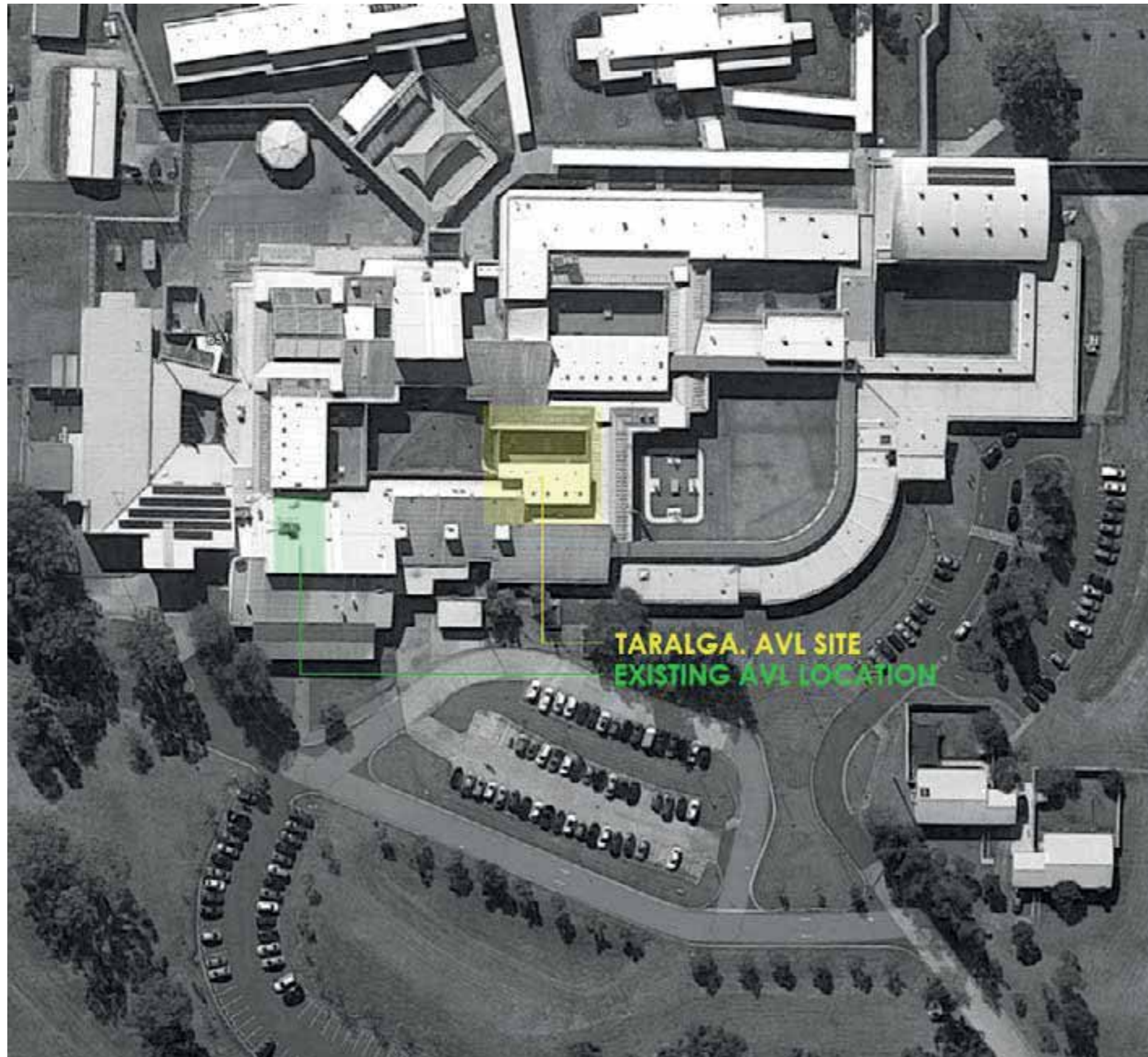

## Background to the Cobham Juvenile Justice AVL Facilities

Cobham Juvenile Justice Centre (Cobham JJC) is located approximately 48km west of Sydney CBD. It is the principal remand centre in NSW for young males aged 15 years and over. The centre accommodates up to 105 young people predominately from the Sydney metropolitan area. Cobham JJC was selected as the pilot site for the design of an AVL facility. The centre already has a stand-alone AVL suite. The new design proposal relocates the AVL function to a new location within the Centre. The relocation to the Taralga Unit offers a dual function of an admissions diversion unit and the AVL facilities. Cobham staff identified this location and dual function as a means to achieve efficiencies in the AVL court process within the Centre and a more dedicated space to assist recently arrived young people who are likely be released within 1 day.

## Cobham Design Brief

### Taralga video conferencing unit

The project brief asked the UTS design team to design for a dual function video conferencing / admissions diversion unit. Taralga had already been selected by Cobham staff for its central location to the centre and whilst maintaining a strong geographical connection with the administration building. The architectural brief is to design a new AVL facility within the existing Taralga unit. The new facility has to offer the dual function as a legal conferencing facility (court and lawyer AVL) as well as operating as a 'admission diversion unit' for young people who are likely to stay only 1-2 days.

The facility is to have the following functions:

- Three court AVL suites
- Staff office for five people
- An orientation room

These functions need to have, or exhibit the following qualities:

- Good sight lines from the office to the Taralga unit
- Good acoustics within and external to the AVL facility
- A sense of being in court
- Good natural and artificial light

# Design Considerations

---

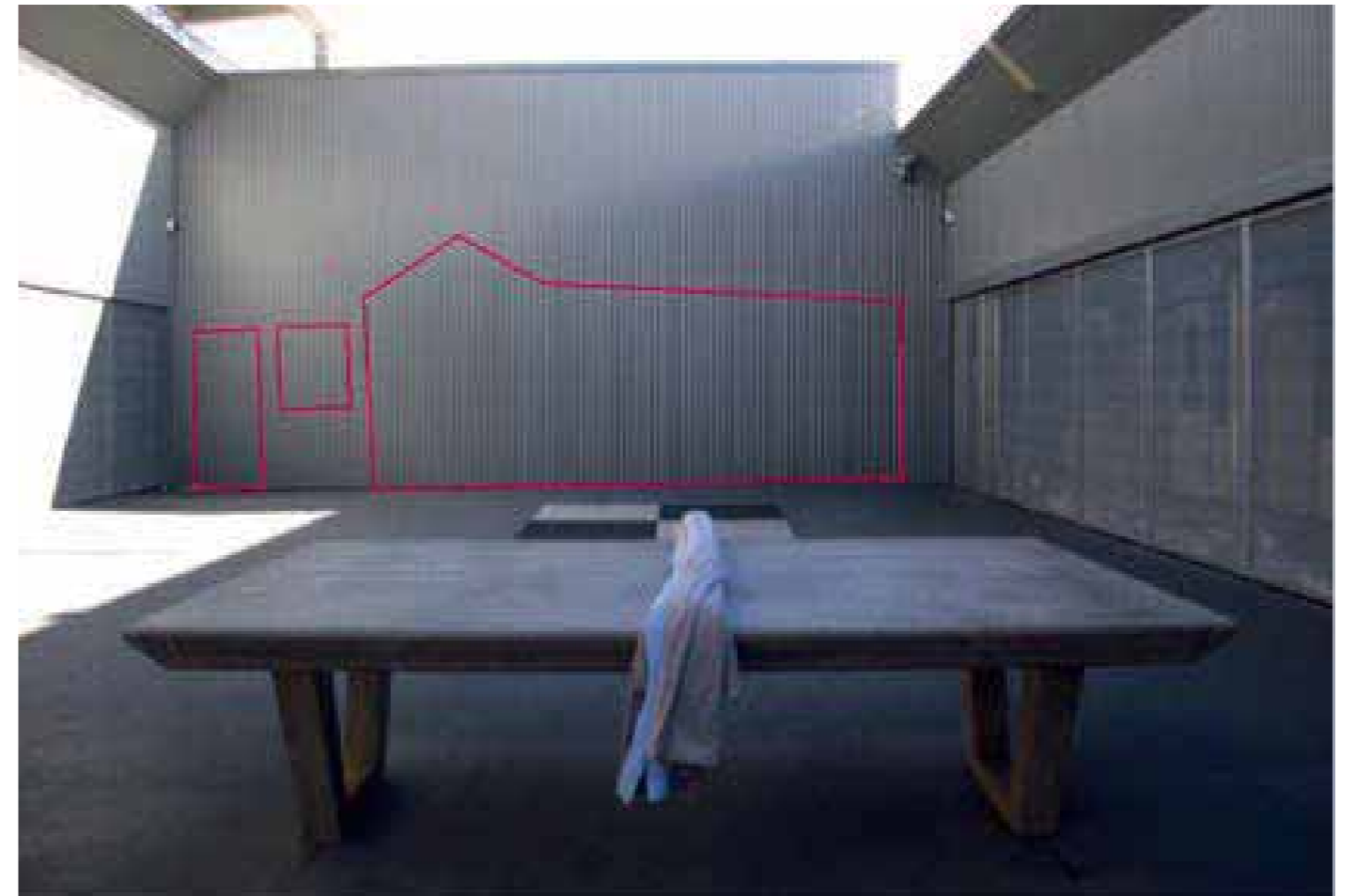

## Site Restrictions

---

Taralga is an operating unit and is used as a residential facility. The unit is fully enclosed around a courtyard. Two sides of the unit are taken up entirely with cells opening to a courtyard whilst another is the rear façade of the administration building. There are some existing small AVL suites in this part of the unit, but they are not considered to be appropriate as a long term AVL court studio solution.

The final side of the courtyard is a colourbond clad wall that separates Taralga from a garden area between other buildings. In front of this wall, there appears to be some significant in ground services as there are a number of service access covers in the concrete.

Placing the AVL studios and office in the courtyard was not an option as the footprint was too large for the courtyard and would have severely impacted

on the amenity of the unit and the services. The only option is to look beyond the walls of Taralga. The colourbond wall separating the courtyard and the adjoining garden are seen as the only option to make the AVL facility intervention. The proposal is to cut the shape of a 'Legal House' in the colourbond wall which will join a prefabricated AVL facility positioned in the adjacent courtyard.

## Framing – 'The Legal House'

---

The frame used to inform the design is the 'Legal House'. It responds to a number of influences in the space:

- The young people are in a temporary 'admissions diversion unit' and only likely to stay a couple of days. It is likely that they will be suffering a level 'shock' as they find themselves in a foreign environment
- The existing Taralga building fabric is monotonous in its use of hard materials and grey shades, further promoting the sense of 'shock' for new arrivals. These do not communicate 'you are now in a court facility'

The 'Legal House' frame is used to inform a design which communicates the objectives of the design, which are:

- To encourage the defendant to Re-center - to focus on court and what they need to do and change outside to get back on track
- Provide a place that's safe - where people are honest about good and bad. Knowledge is available. Engage young people to think what they need to do outside. engage in activities that support reflection and engender hope

## Concept Render - Taralga AVL Facility, Cobham JJC



### Form and materials

The design looks to combine the familiarity of the residential form with the significance of the courthouse. Whilst the existing Taralga architecture does not offer visual cues to young people or staff to guide appropriate court behaviour the design of the Legal House seeks to offer these cues in the form and use of materials. Residential or small, light industrial shapes applied to the existing Taralga building fabric provide a sense of familiarity to the eye. The materials draw from contemporary court design and aims to communicate the gravity of a legal environment, promoting the understanding that defendants are entering court.

The facade is clad with timber, referencing a formal court entrance, a change in materials also creating a threshold, moving from a correctional setting into a legal setting. Stone tiles which extend from the hallway out into the entrance alcove also work to create formality and delineate the space. The stone tiles create a small step up, an action that intends to add to the ritual of entering a formal court space.

A glass door at the entrance looks through a generous hallway to a window at the rear of the space. This floods the hall with light and views to the courtyard beyond the AVL facility. This aims to add to the grandness of the space but

also creates transparency to contribute to a feeling of safety. Views to the garden also intended to provide defendants with a moment to Re-centre themselves before enter the AVL room.

# Facility Design Plan



## Amenity

Adjacent is the concept design for establishing an AVL facility within the existing Taralga unit that has a dual function that includes AVL facility as well as operating as a 'admission diversion unit' for young people who are likely to stay only 1-2 days. Young people who would go to diversion unit would be those with few prior admissions and who would also be likely to have AVL appearances during their time in custody.

- Joining the AVL facility to the Taralga unit allows staff to move defendants between holding cells, the yard and the AVL facility.
- The proposed design includes the addition of a prefabricated AVL facility that includes three AVL rooms, adjoining hallway, entrance alcove and AVL staff office.
- The alcove acts as a formal entrance and provides a waiting space different from the Taralga yard.
- The hallway extends the formal entrance but also create a semi private space for defendants to Re-center themselves before or after their court appearance.
- A soft seating area at the rear of the hall offers a place for defendants to wait before their AVL appearance or to take a moment to process their experience before returning to the yard.
- There are three AVL rooms which extend off the central hallway, the design of these are detailed in the following section.
- This concept also includes the refurbishment of the current recreation room into an orientation room. A place to prepare for court, this could include access to legal resources, somewhere to meet with a youth worker, write notes or have an AVL family visit.
- The existing Taralga AVL studios could be refurbished into legal suites.

# Appearing in Court

*The Interface Design*



# Court Interface Design Concept

---



## Introduction

---

The court interface configuration shown left is a proposed concept for a reimagined experience of the court-custody AVL process which would have impact at both court and custodial ends. The concept has been developed through consideration of technical aspects such as ergonomics, and camera framing as well as through consideration of visceral qualities such as the courtroom presence of the virtual defendant and the aesthetics of formality.

## Intentions

---

The proposed concept for interface configuration intends to recommend an improved setup of equipment in courtrooms with a particular focus on cameras and displays. By addressing both challenges and opportunities presented by the current implementation of AVL, this concept aims to improve the provision of justice through better delivery of the AVL service in courtrooms. Fundamentally, the concept aims to create a more tangible court experience and increased engagement with AVL judicial processes for all involved.

## Testing Procedure Overview

---

The concept was developed through a co-design process with magistrates, lawyers, a police prosecutor and numerous court staff who worked in conjunction with the DOC research team to analyse both current and hypothetical courtroom AVL configurations through qualitative testing. Some of the qualitative measures employed through design development include consideration of equivalence of engagement, virtual courtroom hierarchy through camera placement, clarity of expressions and gestures and seamless integration into various courtroom environments.

# Design Attributes

---

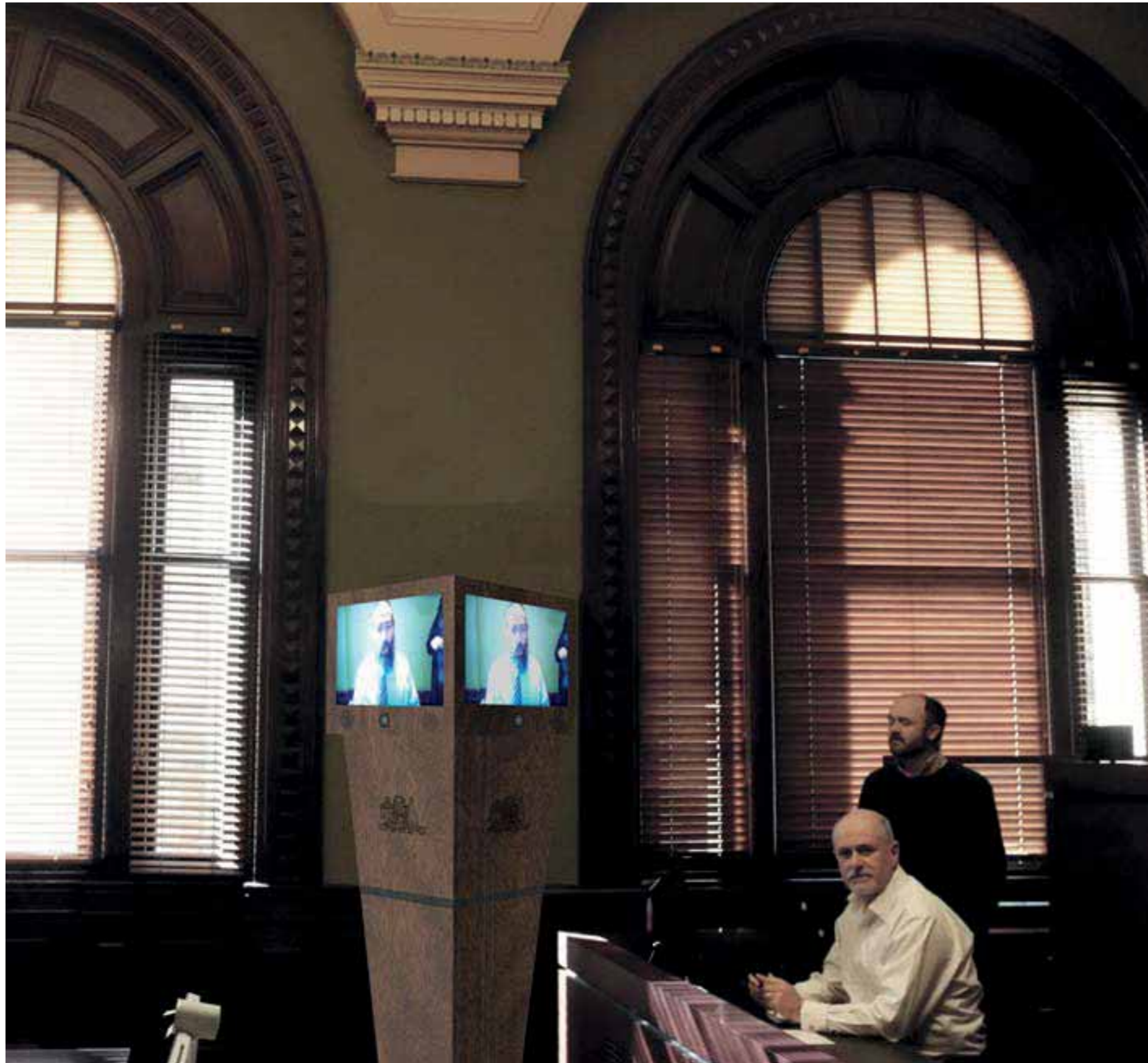

## Situating the Virtual Defendant

---

The proposed concept recommends a dedicated set of displays to show the defendant, with cameras co-located. One pairing of display and camera is angled towards the bench while the other is angled towards the bar table and public gallery. Each display is co-located with a camera so that the defendant can see people's faces when they are conversing with one another. By locating both sets of displays together in the courtroom the virtual defendant is able to appear in court as if they are a tangible entity. Having the displays and cameras enclosed in cabinetry further emphasises the physical presence of the defendant in the courtroom.

## Formalising the View

---

Building the displays into an enclosure provides the opportunity to frame the view of the defendant in cabinetry that matches the court. This can help formalise the view; appropriately framing the court's view of the defendant intends to support due process and their presumption of innocence. The enclosure will help to connect the presence of the defendant with the rest of the court proceedings in a similar way to how a dock works. A court emblem could also be printed on the surface of the cabinetry.

## Courtroom Hierarchy

---

The configuration, placement and cabinetry of this concept have all been designed with consideration of the flexibility required for universal applicability to a variety of courtrooms. The placement of the virtual defendant within the courtroom attempts to least disrupt the court hierarchy by remaining close to the wall but still creating a defendant 'presence'. Lowered displays and cameras aid in creating a more natural interaction.

# Technological Considerations



Current court camera setup



Proposed court camera setup

## Defendant's View of Court

The defendant in custody has a view of the court that is determined by the configuration of cameras within the courtroom. The camera positioning, angle, zoom and framing all play a part in creating a particular view of the court and with tweaking can improve the AVL experience. A common opinion found in the research was that courtroom cameras were currently installed too high with the resulting framing of the bench and bar table inappropriate. The proposed concept lowers the cameras - creating a more natural interaction and improved courtroom hierarchy. In particular, the view of the judge or magistrate would include part of the bench and an increased sense of formality.

## Courtroom Engagement

Lowering the displays and appropriately situating the virtual defendant within the courtroom space strives to make the AVL a more understandable process. As shown in the image to the right, the inclusion of additional speakers within the virtual defendant cabinetry provides directional sound along with sound from standard courtroom speakers. By co-locating speakers with displays, people are encouraged to naturally turn towards the sound and hence the display when the remote participant is speaking. This design consideration aims to aid the AVL process by enabling a higher level of immersion and engagement through proceedings as well as a more realistic manner of communication.





# Proposed Onscreen Layout

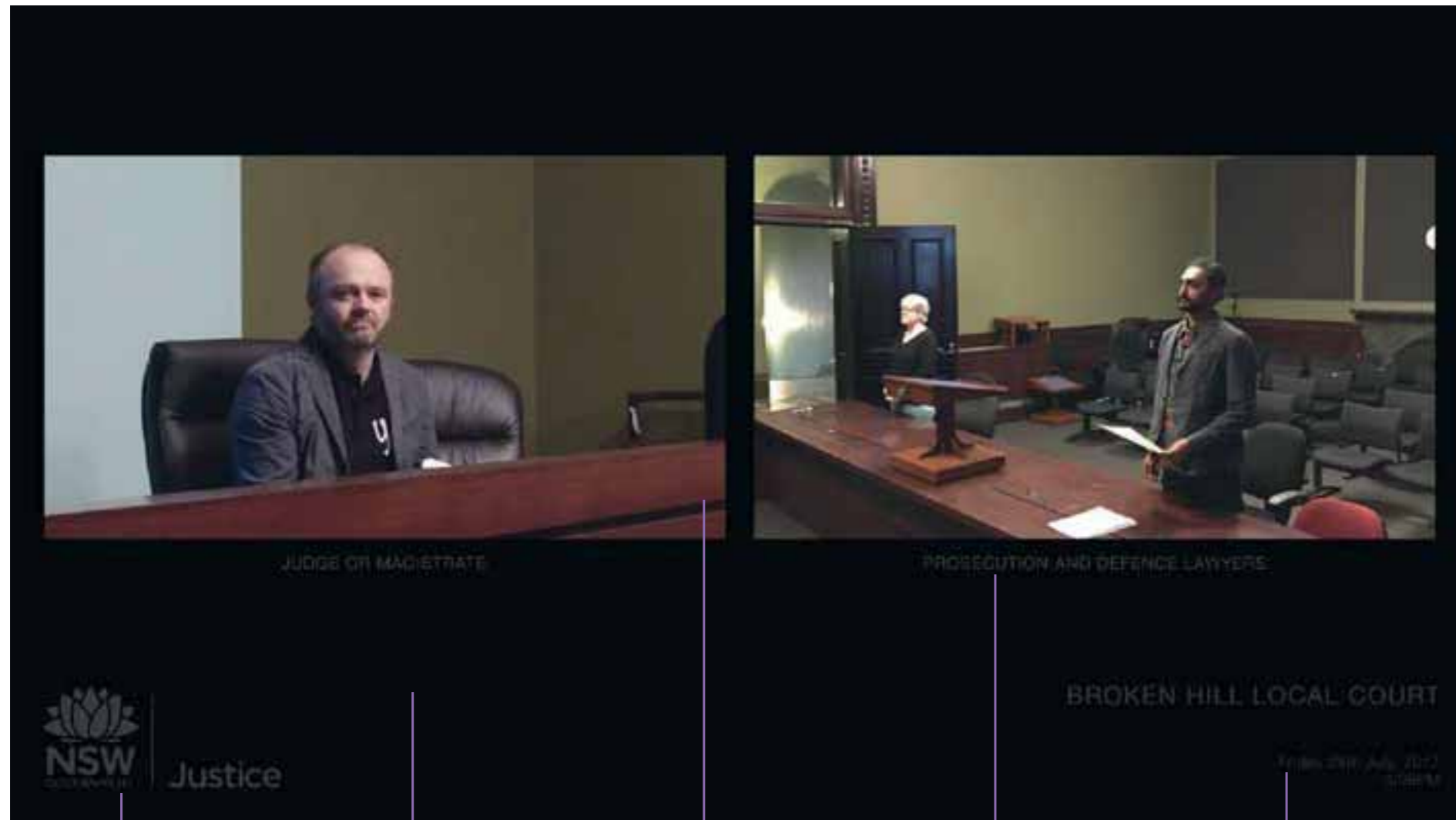

The concept shown depicts what a defendant might see when they are connected to court via AVL. Research found that the current onscreen view was subpar, with a large amount of distracting white space and an arrangement that lacked formality. The concept proposed attempts to help keep the focus mainly on the video feed itself and has the following features as annotated.

1. Partially transparent and reduced size logo
2. Black background to prevent distraction; eyes naturally drawn to light and movement
3. Video frame raised up such that eye height of people at bench and bar table will be equivalent to that of defendant
4. Laymans terms for naming; text placed below video frame
5. Pertinent information displayed unobtrusively; partially transparent; courtroom conference call number omitted

# Conclusion & Recommendations

---

# Conclusion & Recommendations

---

## Conclusion

It is important the NSW justice system is experienced as one which is fair, where all participants have a voice and are heard, the judicial process is encountered as neutral, and defendants are treated with respect. The increasing use of audio visual links to connect people in custody with a court undoubtedly changes aspects of the traditional justice process and peoples' experiences of it. This project sort to understand the current challenges and opportunities created by the use of AVL to develop a range of products and designs to improve people's experience and uphold the values of the justice system. To do this a collaborative co-design approach was utilised to consider the whole AVL ecosystem including the justice processes, technology, spatial design, roles and orientation processes both in custody and the court.

In understanding people's experience and developing new products it was important to find a new way to think productively about the AVL court process and the current difficulties. Key themes that emerged were clarity, engagement and visibility in the court process. Wayfinding and the associated literature emerged as a useful basis for re-considering how to improve all participants' navigation of the AVL court process. The resulting Wayfinding framework articulates eight broad strategies to improve people's navigation of the justice system using AVL facilities. This framework is valuable for understanding the rationale behind the designs and products created in this project, but also importantly for the development of new concepts for improving the AVL experience. While the scope of this project was reasonable wide, undoubtedly there are many other aspects of the system that could be improved.

This project delivers a range of resources, products and spatial designs. Collectively they represent a substantial resource for improving people's experience before, during and after AVL court appearances. The resources and designs look to impact positively on the experience of staff and defendants in custody, and those working within the court. Implemented appropriately, and with consideration of the other recommendations in this report, we believe these resources, products and spatial designs will impact significantly on all AVL participants' experiences of the justice process. They will assist participants to better navigate the AVL court process and perceive the related justice processes as fairer, more neutral and respectful.

## Recommendations

This report concludes with important recommendations regarding; i) implementation planning, ii) any outstanding issues, and iii) ongoing research and development.

### i) Implementation planning

These recommendations relate to the implementation of the resources and designs developed in this project.

#### Recommendation 1: Formal organisational endorsement

Obtain formal organisational endorsement from the Executive (or relevant delegates) for the report and for proceeding to implementation planning and budgets. This should occur within each of the relevant agencies including the Justice Department, Juvenile Justice, Corrective Services NSW and Legal Aid NSW.

#### Recommendation 2: Develop product implementation plans including piloting

Establish implementation plans for the piloting and rollout of the products produced in this project. It is important this includes a process of piloting and review before the rollout. Separate plans should be developed for:

- orientation resources in juvenile justice (female & male)
- orientation resources in adult corrections (female & male)
- AVL studio design in juvenile justice
- AVL studio design in adult corrections

#### Recommendation 3: Concept development and distribution plans

Establish plans for developing relevant design concepts produced in the project. These design concepts require additional development or engagement with the relevant business units before piloting or implementation. Separate plans should be developed for:

- the court room display concept (pg X)
- alternative screen layout concept (pg X)
- juvenile AVL support facility concept (law house, pg xx)

#### Recommendation 4: Implementation governance and reporting

Establish a project implementation group with representation from the relevant organisations and reporting links to the executive (or relevant delegates) in each organisation.

#### Recommendation 5: Resourcing and responsibilities

When in operation AVL rooms in custody are officially a jurisdiction of the court. Currently the responsibility for the design and maintenance of the AVL room is primarily with the custodial facility. Consideration could be given to the Court jurisdiction having greater responsibility and authority to ensure the AVL facilities in custody are consistent with the expectations of the court.

#### Recommendation 6: Monitoring and evaluation

Monitoring and evaluation processes are required to assess the effectiveness of the various products and initiatives. These processes need to be documented in the implementation plans and overseen by the implementation group.

### ii) Outstanding issues

This project also identified some important issues outside of the specific scope of this project. We outline these issues to inform and support the Justice departments' work around improving AVL experiences and processes. It is also acknowledged the Justice department is currently developing initiatives around these issues.

#### Recommendation 7: Improve AVL waiting and holding areas

There is a critical need to improve the amenity and quality of holding and waiting areas for AVL in adult and juvenile custodial institutions. In many facilities the spaces were too small, lacked basic amenity (cooling, heating) and did not portray a sense of human dignity. This impacts on defendants experience of the court and justice process, and creates additional difficulties for staff in doing their work.

#### Recommendation 8: Provide access to custody telephone systems in waiting and holding areas

In most other areas of the custody environment inmates and detainees have access to the telephone system that enables them to call approved numbers.

# Conclusion & Recommendations

---

For example in the adult jurisdiction phones are in the accommodation units and all work areas. We recommend custody phones also be installed in the AVL area as defendants are often in this space for the whole day and there are many examples where access to a phone to call family or friend would be relevant. We understand there is currently investigations into this occurring in some facilities.

## Recommendation 9: Assistance for hearing impaired

Through the research it was identified that many people appearing in court have hearing impairments. Indigenous defendants in particular are more likely to have a hearing impairment. Within the court itself this is addressed through hearing loops and other technology. AVL facilities in both juvenile and adult facilities should also be equipped with this and any other equipment that could significantly assist people with hearing impairments to appropriately engage in the court processes.

## Recommendation 10: Non-institutional clothing for defendants

Under the legislation people appearing in court need to be provided the opportunity to wear their own clothes. When defendants attend court in person they often do elect to wear their own clothes or use formal clothes made available by the centre. When defendants appear via AVL in juvenile and adult facilities it is not common for them to have the option to wear clothes other than their institutional prison clothing. It is apparent from discussions in this project and research by McKay (2017) that only having the option to wear a prison uniform to court could erode defendants and other participants' perceptions of neutrality and respect. We recommend establishing a pilot program in adult and juvenile custody where defendants can opt to access non-institutional clothing for their AVL court appearances. The pilot should be evaluated with consideration for rolling out across all facilities.

## Recommendation 11: Resources for judicial officers, lawyers, court staff, witnesses and custodial staff relating to AVL appearances

Investigate orientation and guidance resources for other people working and participating in court processes where AVL is being used. The use of AVL changes aspects of the court process and experience that can lead to confusion and misunderstanding for people working in the system. Judicial officers, lawyers, court staff, witnesses and custodial staff all need to understand how AVL impacts the process and how they are best to interact.

## Recommendation 12: Technological and system improvements

A number of key technological and systems improvements outside of this project would significantly improve people's experience of AVL. We understand that initiatives are currently being considered or developed for each of these issues. The three aspects are:

- Development of a scheduling system for AVL court appearances that reduces the amount of time defendants in custody typically need to be waiting in a holding area.
- Investigate the use of a Virtual Meeting Room connection system that would assist in managing the virtual transitions into the court and the provision of resources to orientate to defendant.
- Investigate and pilot the use of messaging systems between AVL custody staff, court staff and lawyers. These could greatly improve staff's experience and the efficiency of the system

## iii) Ongoing research & development

There are many drivers that lead to it moving fast and potential opportunities are created with the development of technology.

Suggested areas of research for the justice department to pursue to support and inform the future development of AVL in the justice system.

# Endnotes

---

1. Department of Justice (NSW) Annual Report 2015/16 p. 86; goal is 75% for court appearances: Paget, J., 2015. Full House: The growth of the inmate population, Department of Justice Inspector of Custodial Services, NSW, p. 68.
2. Department of Justice (NSW) Annual Report 2015/16 p.101.
3. *ibid* p.133: the justice values are service, trust, accountability, integrity and respect.
4. The most recent empirical study focusing on the experience of prisoners in an Australian context has been completed by Dr Carolyn McKay. See: McKay, C.L., 2016. Audio visual links from prison: prisoners' experiences of video technologies for accessing justice, PhD Thesis, University of Sydney; Forell, S., Laufer, M. and Digiusto, E., 2011. Legal assistance by video conferencing: what is known?. *Justice issues*, (15), p.1. <http://search.informit.com.au.ezproxy1.library.usyd.edu.au/documentSummary;dn=277169577881456;res=IELAPA>ISSN: 1327-3248>. accessed 23/06/16.
5. Rowden, E., 2011. Remote participation and the distributed court: an approach to court architecture in the age of video-mediated communication, PhD Thesis, University of Melbourne; Wallace, A., 2011, Justice and the 'virtual' expert: using remote witness technology to take scientific evidence, PhD thesis, University of Sydney.
6. Rowden, E., Wallace, A., Tait, D., Hanson, M. and Jones, D., 2013. Gateways to justice: Design and operational guidelines for remote participation in court proceedings.
7. Evidence (Audio and Audio Visual Links) Act 1998 (NSW) and Evidence (Audio and Audio Visual Links) Regulation 2015 (NSW).
8. Rowden, E., Wallace, A., Tait, D., Hanson, M. and Jones, D., 2013. Gateways to justice: Design and operational guidelines for remote participation in court proceedings.
9. *ibid*.
10. Babcock, E. and Johansen, K., 2010. Remote Justice-Expanding the Use of Interactive Video Teleconference in Minnesota Criminal Proceedings. *Wm. Mitchell L. Rev.*, 37, p.652; Rowden, E., Wallace, A. and Goodman-Delahunty, J., 2010, Sentencing by videolink: up in the air? *Criminal Law Journal*, 34 (6) pp. 363-384.
11. McKay, C., 2015. Video Links from Prison: Court "Appearance" within Carceral Space. *Law, Culture and the Humanities*, p.1743872115608350; McKay, C.L., 2016. Audio visual links from prison: prisoners' experiences of video technologies for accessing justice, PhD Thesis, University of Sydney.
12. Ashdown, G.G. and Menzel, M.A., 2002. The Convenience of the Guillotine: Video Proceedings in Federal Prosecutions, *Denver University Law Review*, 80, p.63; Mack, K., 2012. Legal architecture: justice, due process and the place of law by Linda Mulcahy: Representing justice: invention, controversy, *Journal of Law and Society*, 39(2), pp.317-325.
13. Rowden, E., 2011. Remote participation and the distributed court: an approach to court architecture in the age of video-mediated communication, PhD Thesis, University of Melbourne; Grunseit, A., Forell, S. and McCarron, E., 2008. Taking justice into custody: the legal needs of prisoners <http://search.informit.com.au.ezproxy1.library.usyd.edu.au/documentSummary;dn=201215075;res=IELAPA>ISSN: 1327-3248>. accessed 23/06/16; Terry, M., Johnson, S. and Thompson, P., 2010. Virtual Court pilot Outcome evaluation. Ministry of Justice, London; Ward, J., 2014. Transforming 'Summary Justice' Through Police-Led Prosecution and 'Virtual Courts' Is 'Procedural Due Process' Being Undermined?. *British Journal of Criminology*, 55(2), pp.341-358; McKay, C., 2015. Video Links from Prison: Court "Appearance" within Carceral Space. *Law, Culture and the Humanities*, p.1743872115608350; McKay, C.L., 2016. Audio visual links from prison: prisoners' experiences of video technologies for accessing justice, PhD Thesis, University of Sydney.
14. Tyler, T.R., 2007. Procedural justice and the courts. *Court Review*, 44, pp.26-164; Burke, K. and Leben, S., 2007. A White Paper Of The American Judges Association The Voice Of The Judiciary (R): Procedural Fairness: A Key Ingredient In Public Satisfaction. *Court Review*, 44, pp.4-164; Rowden, E., 2011. Remote participation and the distributed court: an approach to court architecture in the age of video-mediated communication, PhD Thesis, University of Melbourne; McKay, C.L., 2016. Audio visual links from prison: prisoners' experiences of video technologies for accessing justice, PhD Thesis, University of Sydney.
15. Tyler, T. R., 2005. Introduction. In T. R. Tyler (Ed.), *Procedural justice: Volume I. Procedural justice and the dynamics of authority* (Vol. 1, pp. xi-xxiii). Burlington, V.T: Ashgate, xv.
16. Mulcahy, L., 2011. *Legal architecture: Justice, due process and the place of law*. Routledge; Terry III, W.C. and Surette, R., 1985. Video in the Misdemeanor Court: The South Florida Experience. *Judicature*, 69, p.13; Rowden, E., 2011. Remote participation and the distributed court: an approach to court architecture in the age of video-mediated communication, PhD Thesis, University of Melbourne; McKay, C.L., 2016. Audio visual links from prison: prisoners' experiences of video technologies for accessing justice, PhD Thesis, University of Sydney.
17. Young, J. 2011. A Virtual Day in Court: Design Thinking & Virtual Courts. Paper presented at the RSA Projects and Cisco Systems Seminar, London.
18. Braun, S. and Taylor, J. L., 2011. Video-mediated interpreting: an overview of current practice and research. In Braun, S. & J. L. Taylor (Eds.), *Videoconference and remote interpreting in criminal proceedings*. Guildford: University of Surrey, 27-57: initiatives include setting minimum standards for lighting, seating and duration of AVL sessions.
19. Rowden, E., Wallace, A., Tait, D., Hanson, M. and Jones, D., 2013. Gateways to justice: Design and operational guidelines for remote participation in court proceedings.
20. Heath, W.P. and Grannemann, B.D., 2014. How video image size interacts with evidence strength, defendant emotion, and the defendant-victim relationship to alter perceptions of the defendant. *Behavioral sciences & the law*, 32(4), pp.496-507.
21. McKay, C.L., 2016. Audio visual links from prison: prisoners' experiences of video technologies for accessing justice, PhD Thesis, University of Sydney; McKay, C., 2017. Face-to-interface Communication: Accessing Justice by Video Link from Prison. in *Access to Justice and Legal Aid: Comparative Perspectives on Unmet Legal Need*, p.103;
22. Braun, S. and Taylor, J. L., 2011. Video-mediated interpreting: an overview of current practice and research. In Braun, S. & J. L. Taylor (Eds.), *Videoconference and remote interpreting in criminal proceedings*. Guildford: University of Surrey, 27-57 at 28, 32-3 draw a distinction between 'videoconferencing interpreting' where proceedings are linked between two locations, such as court and prison, and the interpreter is either in the courtroom remote from the prisoner or co-located with the prisoner, versus 'remote interpreting' where proceedings take place in one location, such as a courtroom, and only the interpreter is remote; Braun, S. and Taylor, J., 2011. Video-mediated interpreting in criminal proceedings: two European surveys. in Braun, S. & J. L. Taylor (Eds.), *Videoconference and remote interpreting in criminal proceedings*. Guildford: University of Surrey, 59-84; Fowler, Y. 2013. Non-English-speaking defendants in the Magistrates Court: A comparative study of face-to-face and prison video link interpreter-mediated hearings in England. Dissertation. Aston University.
23. Napier, J., 2011. Here or there? An assessment of video remote signed language interpreter-mediated interaction in court. *Videoconference and remote interpreting in criminal proceedings*, pp.45-83.
24. Wallace, A., 2008. Virtual justice in the bush: The use of court technology in remote and regional Australia. *JL Inf. & Sci.*, 19, p.1.
25. Department of Justice Annual Report 2015-16, p.86; McKay, C., 2016. In focus: Pixels, screens and prison video links: Changing how lawyers deal with clients. *LSJ: Law Society of NSW Journal*, (29), p.24
26. Lulham, R., Kashyap, K. and Rowden, E. 2016. Audio Visual Link Suites in Custodial Contexts working document; de Simone, T. and d'Aquino, C., 2004. Inside Out: The Access of Women and Girls in Custody to Legal Aid Services; McKay, C., 2015. Video Links from Prison: Court "Appearance" within Carceral Space. *Law, Culture and the Humanities*, p.1743872115608350; McKay, C., 2016. Video Links from Prison: Permeability and the Carceral World. *International Journal for Crime, Justice & Social Democracy*, 5(1); McKay, C., 2016. In focus: Pixels, screens and prison video links: Changing how lawyers deal with clients. *LSJ: Law Society of NSW Journal*, (29), p.24; McKay, C., 2017. Face-to-Interface Communication: Accessing Justice by Video Link from Prison, in Asher Flynn and Jackie Hodgson (eds) *Access to Justice: Comparative Perspectives on Unmet Legal Need*, Hart Publishing; Bellone, E.T., 2013. Private Attorney-Client Communications and the effect of videoconferencing in the courtroom. *Journal of International Commercial Law and Technology*, 8, p.24.
27. McKay, C.L., 2016. Audio visual links from prison: prisoners' experiences of video technologies for accessing justice, PhD Thesis, University of Sydney.
28. We note certain exemptions to physical appearance provided by the regulations

# Endnotes

---

- and the prescribed spaces that may be used for bail proceedings: Evidence (Audio and Audio Visual Links) Regulation 2015 (NSW), Reg 4.
29. Evidence (Audio and Audio Visual Links) Act 1998 (NSW), s5C; Attorney General's Department of NSW (2005). NSW Criminal Trials Benchbook: Remote Witness Facilities, operational guidelines for Judicial Officers. PDF file downloaded on 12/05/2010 at [http://www.judcom.nsw.gov.au/publications/benchbks/criminal/evidence\\_given\\_by\\_alternative\\_means.html#p1-384](http://www.judcom.nsw.gov.au/publications/benchbks/criminal/evidence_given_by_alternative_means.html#p1-384).
30. This principle has been articulated in the Netherlands as "True-to-Life", see: van Rotterdam, P., & van den Hoogen, R. 2011. True-to-life requirements for using videoconferencing in legal proceedings. in S. Braun & J. L. Taylor (Eds.), Videoconference and remote interpreting in criminal proceedings (pp. 187-197). Guildford: University of Surrey. Accessed on 17/08/11 at < <http://www.videoconference-interpreting.net/BraunTaylor2011.html>>.
31. McKay, C., 2015. Video Links from Prison: Court "Appearance" within Carceral Space. *Law, Culture and the Humanities*, p.1743872115608350.
32. Rowden, E. 2011. Remote Participation and the Distributed Court: an approach to court architecture in the age of video-mediated communications. Unpublished PhD Thesis. University of Melbourne, Melbourne; Rowden, E., Wallace, A., Tait, D., Hanson, M. and Jones, D., 2013. Gateways to justice: Design and operational guidelines for remote participation in court proceedings.
33. Resnik, J. and Curtis, D.E., 2011. Representing justice: Invention, controversy, and rights in city-states and democratic courtrooms. Yale University Press; Mulcahy, L., 2011. Legal architecture: Justice, due process and the place of law. Routledge; Carlen, P., 1976. THE STAGING OF MAGISTRATES' JUSTICE. *The British Journal of Criminology*, 16(1), pp.48-55; Rowden, E., 2015. Distributed Courts and Legitimacy: What do we Lose When we Lose the Courthouse?. *Law, Culture and the Humanities*, p.1743872115612966; Hanson, J., 1996. The architecture of justice: Iconography and space configuration in the English law court building. *Architectural Research Quarterly*, 1(04), pp.50-59.
34. Bellone, E.T., 2013. Private Attorney-Client Communications and the effect of videoconferencing in the courtroom. *Journal of International Commercial Law and Technology*, 8, p.24; Spaulding, N.W., 2012. Enclosure of Justice: Courthouse Architecture, Due Process, and the Dead Metaphor of Trial. *The Yale JL & Human.*, 24, p.311.
35. Polycom, 2012. Polycom Telejustice Solutions: Collaborative Solutions for Courts and Corrections. <http://www.polycom.com.au/content/dam/polycom/common/documents/data-sheets/polycom-telejustice-solutions-br-enus.pdf> accessed 21/02/15.
36. Hillman, Z.M., 2007. Pleading Guilty and Video Teleconference: Is a Defendant Constitutionally Present When Pleading Guilty by Video Teleconference. *J. High Tech. L.*, 7, p.41; Bellone, E.T., 2013. Private Attorney-Client Communications and the effect of videoconferencing in the courtroom. *Journal of International Commercial Law and Technology*, 8, p.24; Rowden, E., 2011. Remote participation and the distributed court: an approach to court architecture in the age of video-mediated communication, PhD Thesis, University of Melbourne; McKay, C.L., 2016. Audio visual links from prison: prisoners' experiences of video technologies for accessing justice, PhD Thesis, University of Sydney.
37. Hancock, P. and Jewkes, Y., 2011. Architectures of incarceration: The spatial pains of imprisonment. *Punishment & Society*, 13(5), pp.611-629; McKay, C.L., 2016. Audio visual links from prison: prisoners' experiences of video technologies for accessing justice, PhD Thesis, University of Sydney.
38. McKay, C.L., 2016. Audio visual links from prison: prisoners' experiences of video technologies for accessing justice, PhD Thesis, University of Sydney.
39. Department of Justice (NSW) Annual Report 2015/16 p.133
40. Tyler, T.R., 2007. Procedural justice and the courts. *Court Review*, 44, pp.26-164; Burke, K. and Leben, S., 2007. A WHITE PAPER OF THE AMERICAN JUDGES ASSOCIATION THE VOICE OF THE JUDICIARY (R): PROCEDURAL FAIRNESS: A KEY INGREDIENT IN PUBLIC SATISFACTION. *Court Review*, 44, pp.4-164; Rowden, E., 2011. Remote participation and the distributed court: an approach to court architecture in the age of video-mediated communication, PhD Thesis, University of Melbourne; Rowden, E., Wallace, A., Tait, D., Hanson, M. and Jones, D., 2013. Gateways to justice: Design and operational guidelines for remote participation in court proceedings; McKay, C.L., 2016. Audio visual links from prison: prisoners' experiences of video technologies for accessing justice, PhD Thesis, University of Sydney.
41. Rowden, E., 2011. Remote participation and the distributed court: an approach to court architecture in the age of video-mediated communication, PhD Thesis, University of Melbourne; Rowden, E., Wallace, A., Tait, D., Hanson, M. and Jones, D., 2013. Gateways to justice: Design and operational guidelines for remote participation in court proceedings.
42. McKay, C.L., 2016. Audio visual links from prison: prisoners' experiences of video technologies for accessing justice, PhD Thesis, University of Sydney; Dumoulin, L. and Licoppe, C., 2015. Trial at a Distance: Videoconference Technology as a Policy Tool?. In *International Conference in Public Policy* (Vol. 1, No. 5); Licoppe, C. and Dumoulin, L., 2010. The "curious case" of an unspoken opening speech act: A video-ethnography of the use of video communication in courtroom activities. *Research on Language and Social Interaction*, 43(3), pp.211-231; Ward, J., 2014. Transforming 'Summary Justice' Through Police-Led Prosecution and 'Virtual Courts' Is 'Procedural Due Process' Being Undermined?. *British Journal of Criminology*, 55(2), pp.341-358.
43. McKay, C.L., 2016. Audio visual links from prison: prisoners' experiences of video technologies for accessing justice, PhD Thesis, University of Sydney; Poulin, A.B., 2003. Criminal justice and videoconferencing technology: The remote defendant. *Tulane Law Review*, 78, p.1089.
44. Rowden, E., 2011. Remote participation and the distributed court: an approach to court architecture in the age of video-mediated communication, PhD Thesis, University of Melbourne; Rowden, E., Wallace, A., Tait, D., Hanson, M. and Jones, D., 2013. Gateways to justice: Design and operational guidelines for remote participation in court proceedings.
45. McKay, C.L., 2016. Audio visual links from prison: prisoners' experiences of video technologies for accessing justice, PhD Thesis, University of Sydney.
46. Diamond, S.S., Bowman, L.E., Wong, M. and Patton, M.M., 2010. Efficiency and cost: The impact of videoconferenced hearings on bail decisions. *Journal of Criminal Law & Criminology*, 100, p.869; Terry, M., Johnson, S. and Thompson, P., 2010. Virtual Court pilot Outcome evaluation. Ministry of Justice, London; Rowden, E., Wallace, A. and Goodman-Delahunty, J., 2010. Sentencing by videolink: up in the air? *Criminal Law Journal*, 34 (6) pp. 363-384; Plotnikoff, J. and Woolfson, R., 1999. Preliminary Hearings: Video Links Evaluation of Pilot Projects-Final Report; Poulin, A.B., 2003. Criminal justice and videoconferencing technology: The remote defendant. *Tulane Law Review*, 78, p.1089; Ward, J., 2014. Transforming 'Summary Justice' Through Police-Led Prosecution and 'Virtual Courts' Is 'Procedural Due Process' Being Undermined?. *British Journal of Criminology*, 55(2), pp.341-358; Kluss, S., 2008. Virtual justice: the problems with audiovisual appearances in criminal courts. *Law Society Journal: the official journal of the Law Society of New South Wales*, 46(4), p.48; McKay, C.L., 2016. Audio visual links from prison: prisoners' experiences of video technologies for accessing justice, PhD Thesis, University of Sydney.
47. Rowden, E., Wallace, A., Tait, D., Hanson, M. and Jones, D., 2013. Gateways to justice: Design and operational guidelines for remote participation in court proceedings.
48. McKay, C.L., 2016. Audio visual links from prison: prisoners' experiences of video technologies for accessing justice, PhD Thesis, University of Sydney.
49. McKay, C.L., 2016. Audio visual links from prison: prisoners' experiences of video technologies for accessing justice, PhD Thesis, University of Sydney.
50. McKay, C.L., 2016. Audio visual links from prison: prisoners' experiences of video technologies for accessing justice, PhD Thesis, University of Sydney.



---

## Team

---

Kevin Bradley  
Jack Fahy  
Kiran Kashyap  
Lucy Klippan  
Rohan Lulham  
Tasman Munro  
Douglas Tomkin

# Appendices

---



## Appendix 1: AVL Studio Design: Room Dimensions



This AVL Studio is designed for the context of Juvenile Justice which includes the provision of two support staff to be seated behind the defendant. A similar design would apply to an adult context, with the support staff seat removed and the room dimensions reduced to 3600 x 2200.

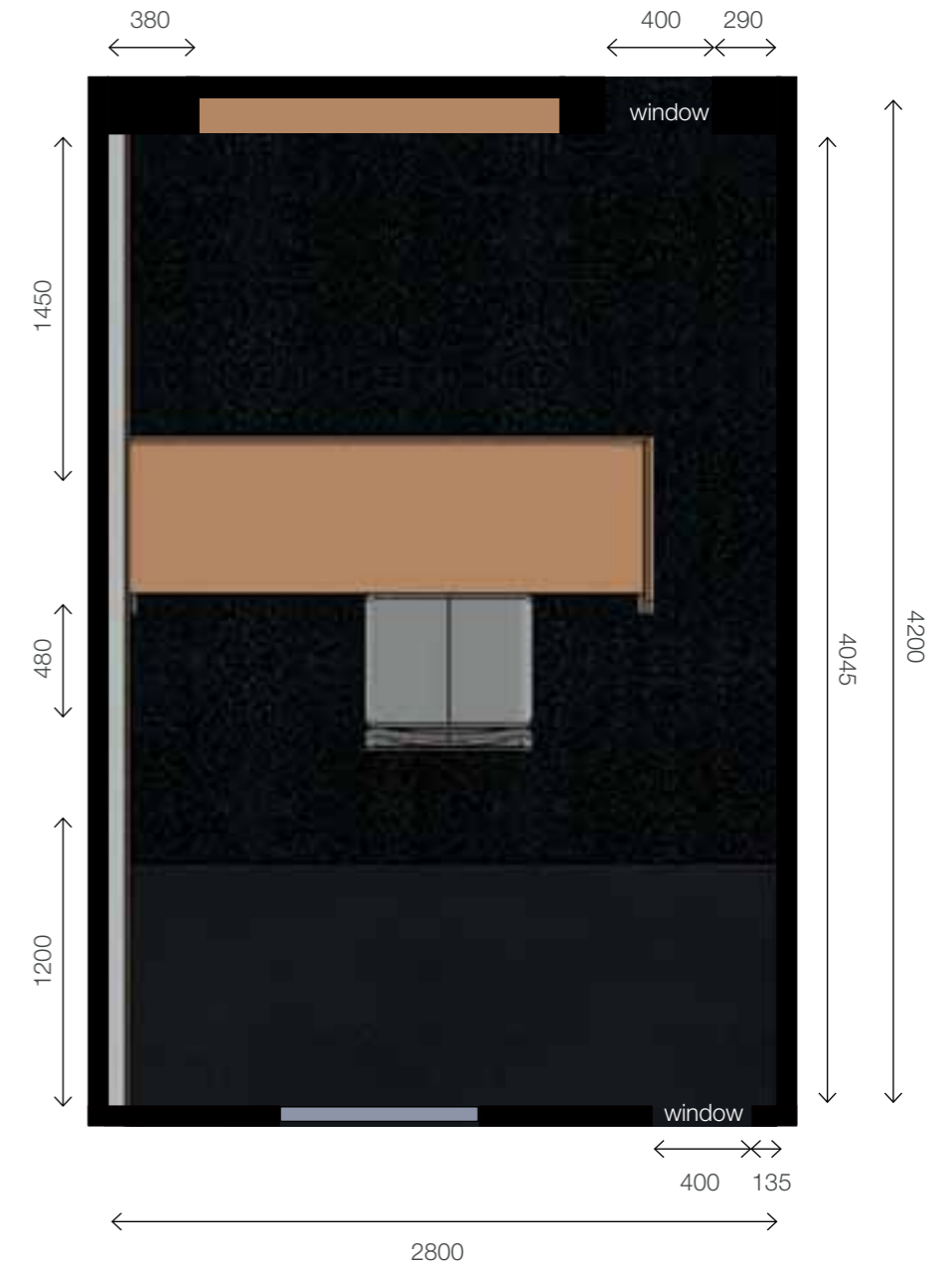

# Appendix 1: AVL Suite Concept: Lighting

The single fluorescent downlights seen in many current AVL studios can create stark shadows on the face and a 'flat' looking image where the person drops into the background.

The proposed design has replaced these with best practice video conferencing as well as photography portraiture lighting which intend to create an evenly illuminated face, and a more three dimension representation of the person in space.

This includes a recessed directional light at the front illuminating the persons face from a front angle, and directional lights illuminating the side and back walls, creating a 'halo' effect - diffused glow behind the person which brings them out of the background.

A similar system is used in AVL studios at Auckland Correctional Centre.



## PicturePhone Hi-Lite Video conferencing lighting

### Unique Features

- Recessed flush-mount enclosure.
- Available in 110, 220-240 or 277 volts.
- Dimmable (built-in infrared or external) or non-dimmable.
- Low-profile construction.
- Directional, diffused light source.
- Removable electronic chassis.

Recessed Hi-Lite Videoconference LightingThe Recessed Hi-Lite Series is the newest addition to PicturePhone's lighting solutions for videoconferencing. The Recessed Series effectively addresses the challenges presented by the modern day boardroom. Ideal for high-end boardrooms and conference rooms, the recessed Hi-Lites provide the high-quality lighting required by the videoconferencing camera without compromising boardroom aesthetics.

Recessed Series Hi-Lites feature multiple dimming options and operating voltages. The XLR model includes a built-in infrared dimmer, the EXR is wired for external three-wire dimming systems, and the NXR is our non-dimming recessed model. All three recessed models include two 50-watt, 3500eK compact fluorescent lamps in a flush-mount, recessed enclosure. Each light also includes an installation kit complete with safety cabling and electrical connectors.

*(taken from [www.rscbroadband.com/Hi-Lite.asp](http://www.rscbroadband.com/Hi-Lite.asp))*

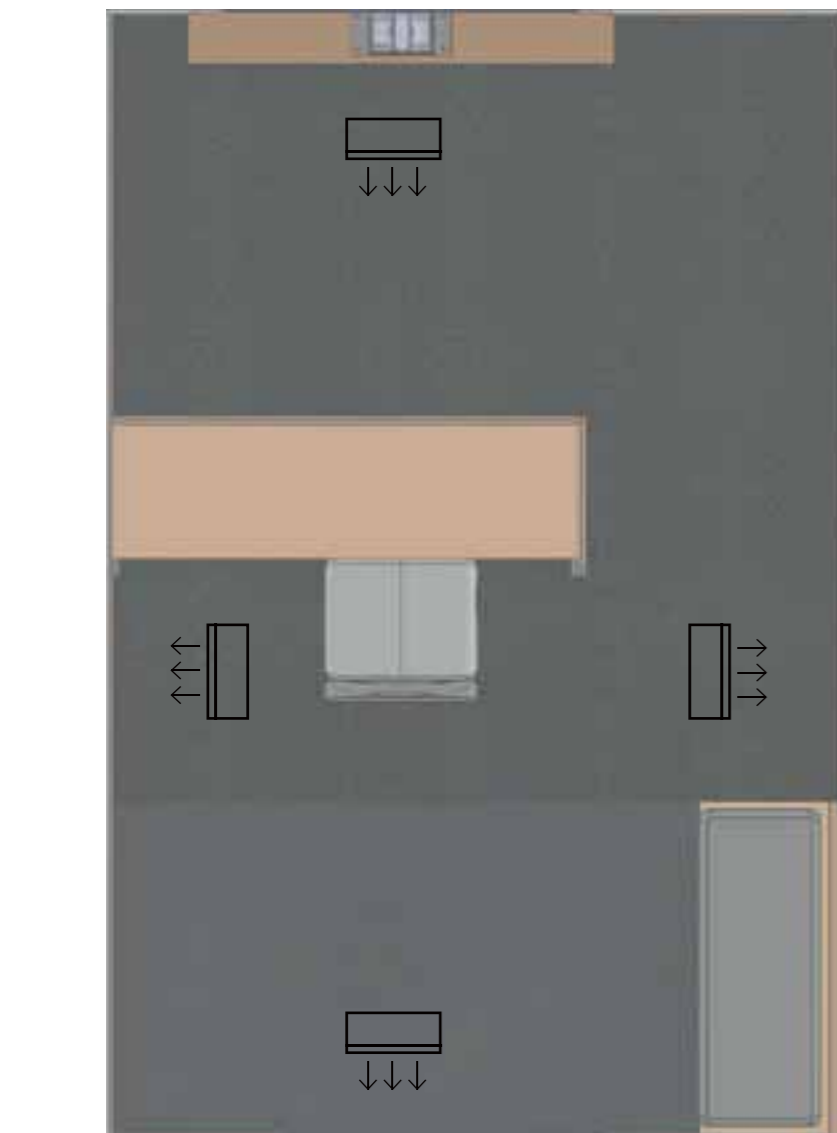

## Appendix 1: AVL Studio Design: AVL Cabinet Details

---



Lexan slides into steel C sections. Can be removed by opening top cupboard

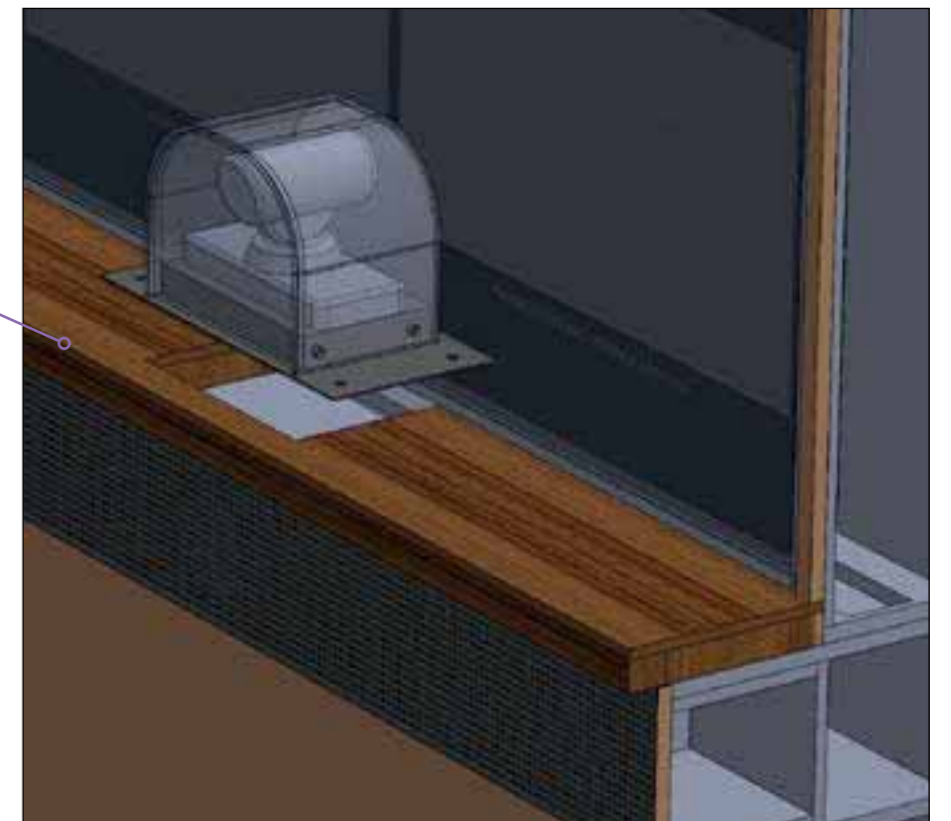

Lexan camera guard mounted from underneath bench and screwed from inside bottom cupboard. Perforated steel guard protects speakers and microphone.

# Appendix 1: AVL Studio Design: Component Materials and Assembly – AVL Cabinet

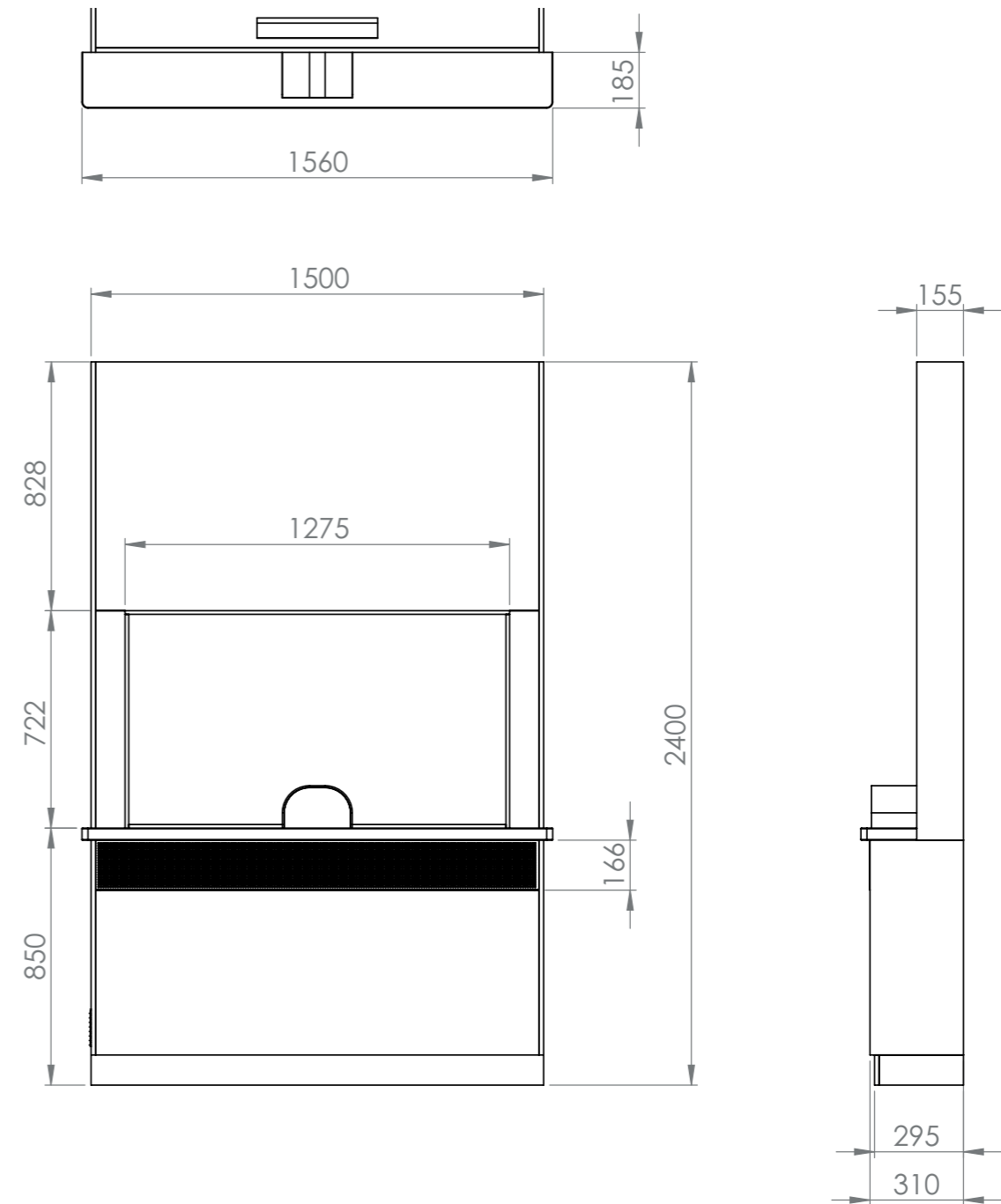
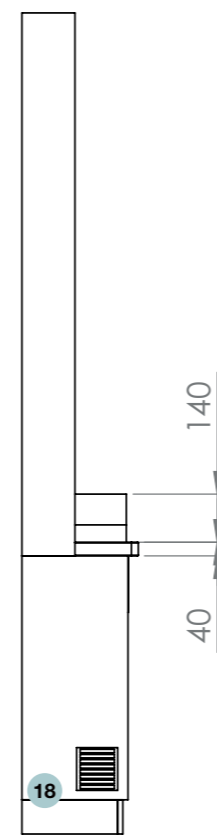
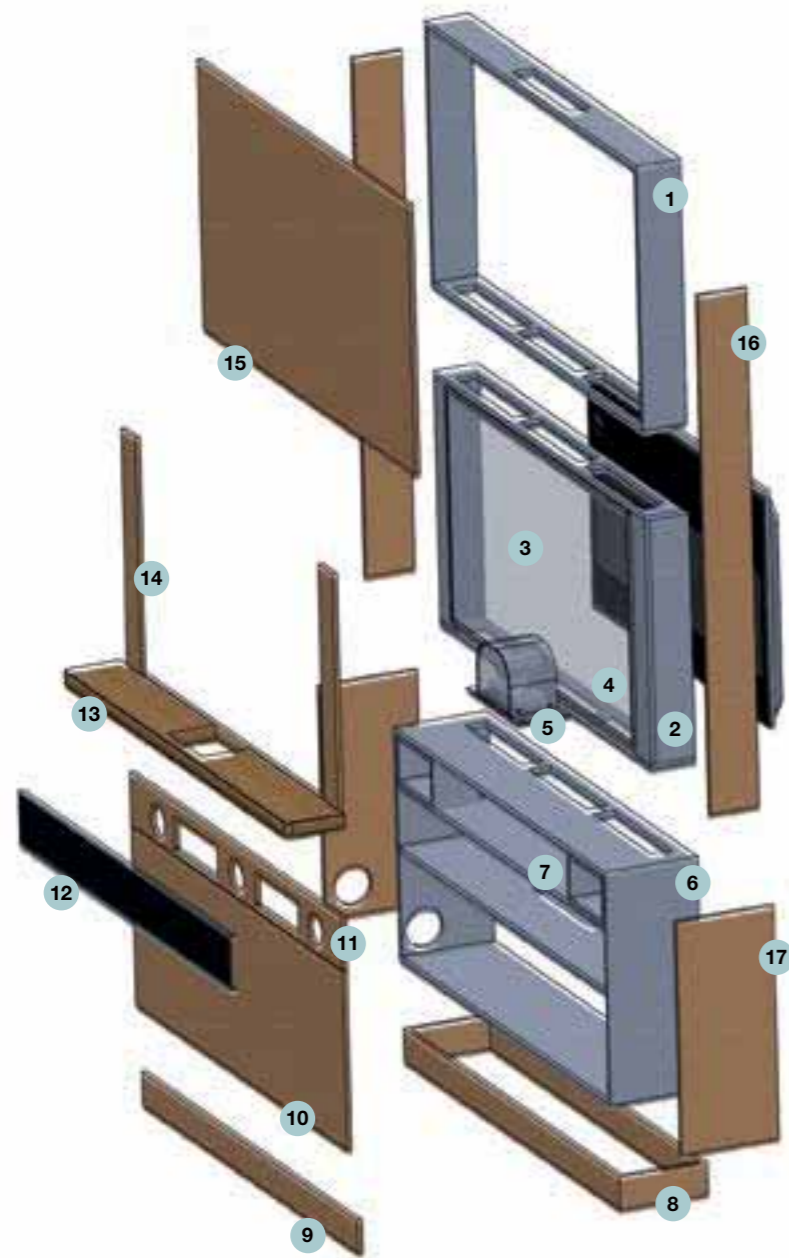

NO.	NAME	MATERIAL
1	Bulkhead	15mm particle Board
2	TV enclosure	15mm Particle Board
3	Screen protector	6mm non glare Lexan
4	Screen protector channel	6mm steel C section
5	Camera guard	6mm Lexan, 3mm steel plate base
6	Bottom cabinet	15mm Particle Board

NO.	NAME	MATERIAL
7	Speaker box	15mm Particle Board
8	Base	15mm ply
9	Base front Plate	15mm Ply
10	Bottom door	15mm Ply
11	Speaker/Mic front	15mm Ply
12	Speaker/Mic guard	1.5mm perforated steel

NO.	NAME	MATERIAL
13	Bench	40mm Blackbutt
14	Facade edges	15mm Ply
15	Top Door	15mm Ply
16	Top Side panel	15mm ply
17	Bottom Side Panel	15mm Ply
18	120 x 125mm Vent	Stainless Steel

# Appendix 1: AVL Studio Design: Component Materials and Assembly

## Defendant Chair

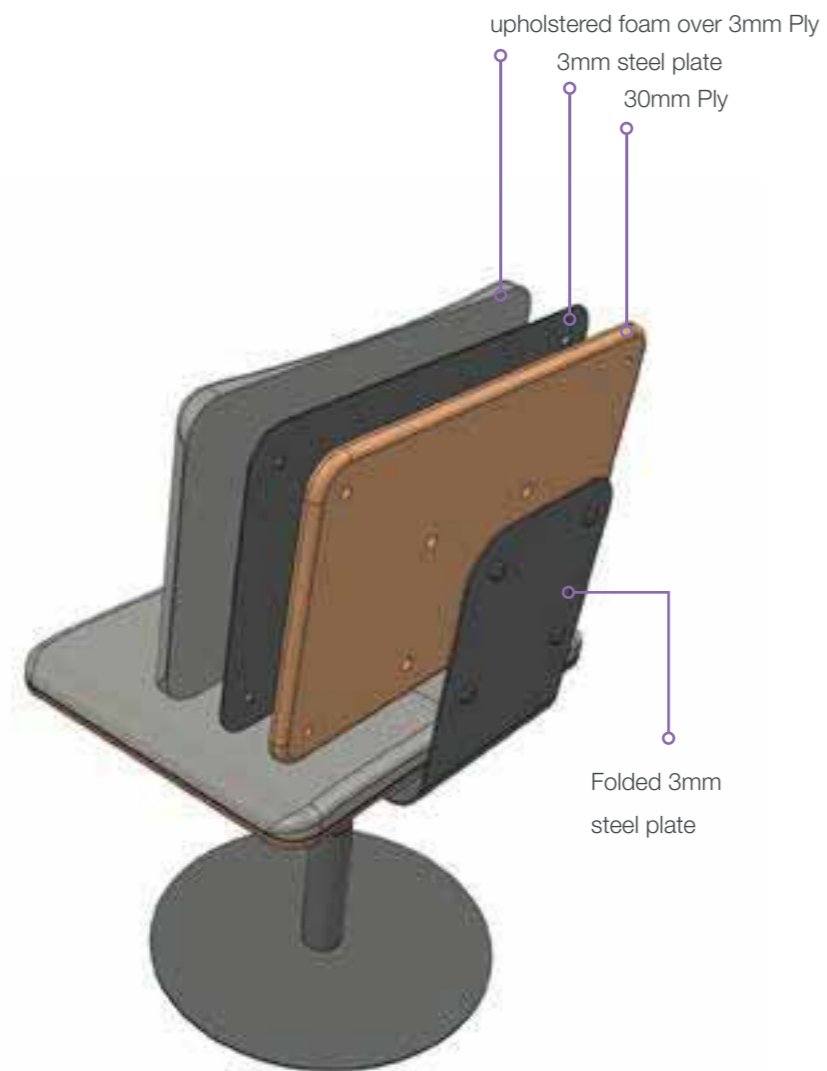

\*At time of prototyping and manufacturer please contact Designing Out Crime for more detailed production drawings

## Signage



Signs printed on Plywood  
Flat bed printing can print in robust enamel directly onto ply [www.blowupimaging.com.au](http://www.blowupimaging.com.au)

### Installation of signage

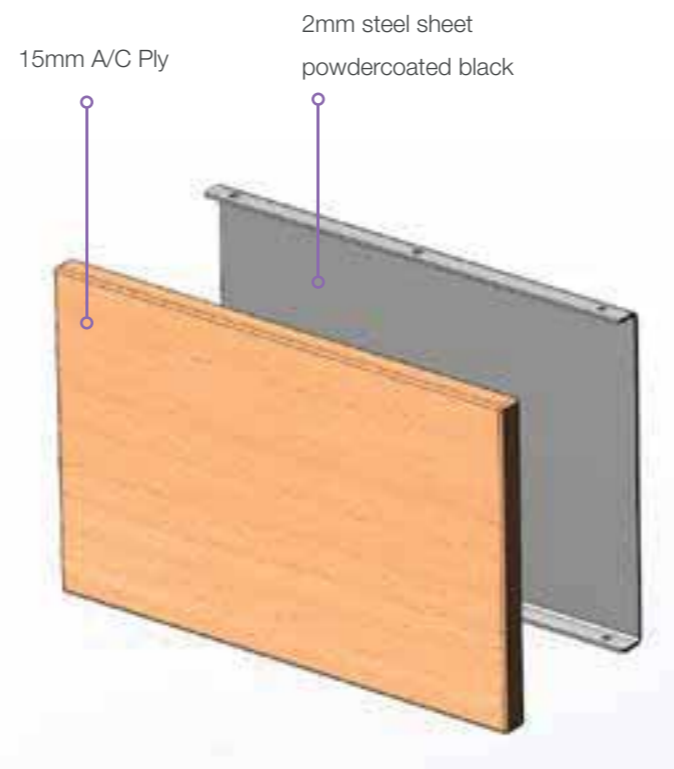

# Appendix 1: AVL Studio Design – AVL Equipment

Cisco Telepresence System + Samsung 55" LED TV (Series 6)

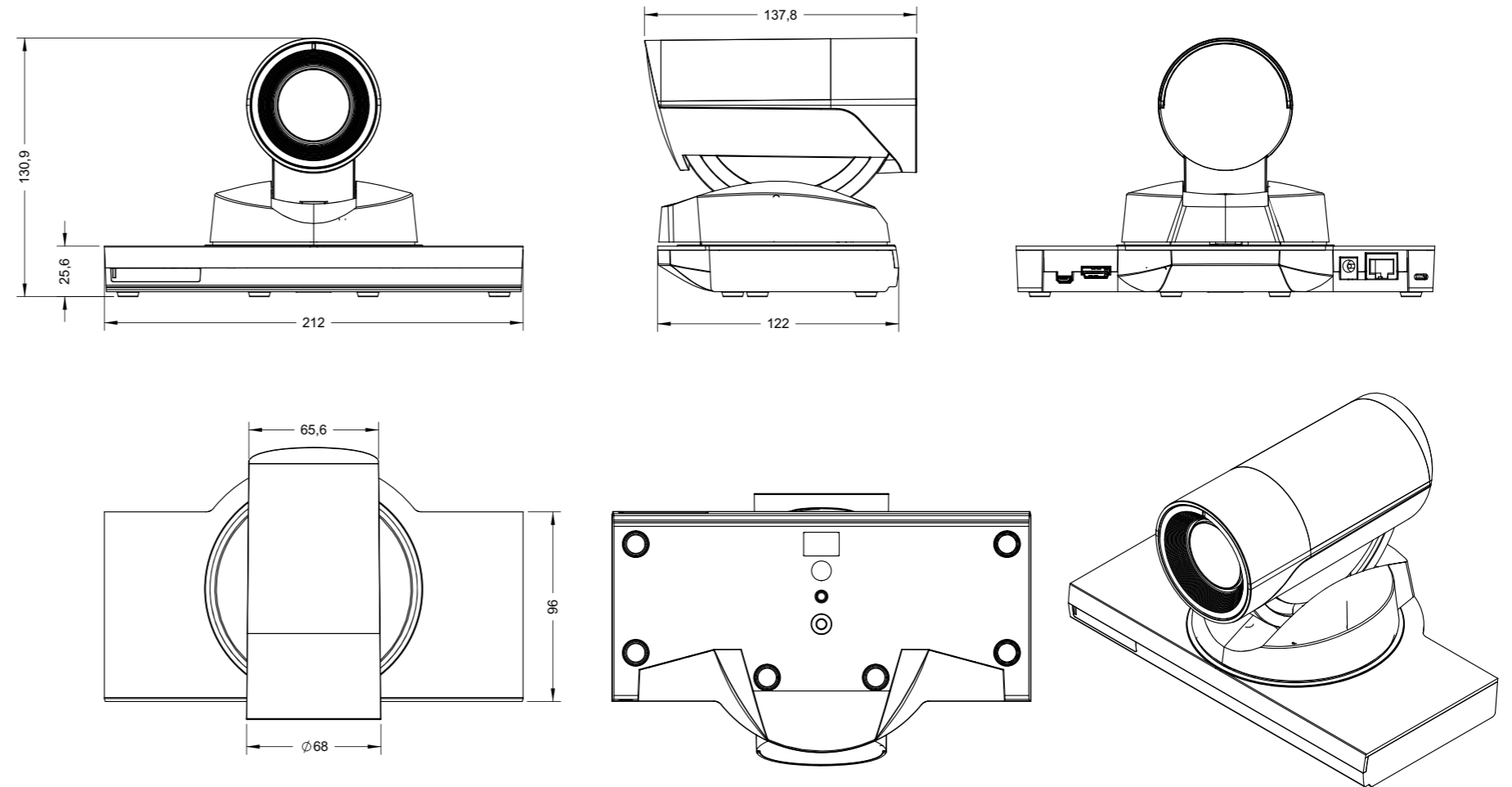
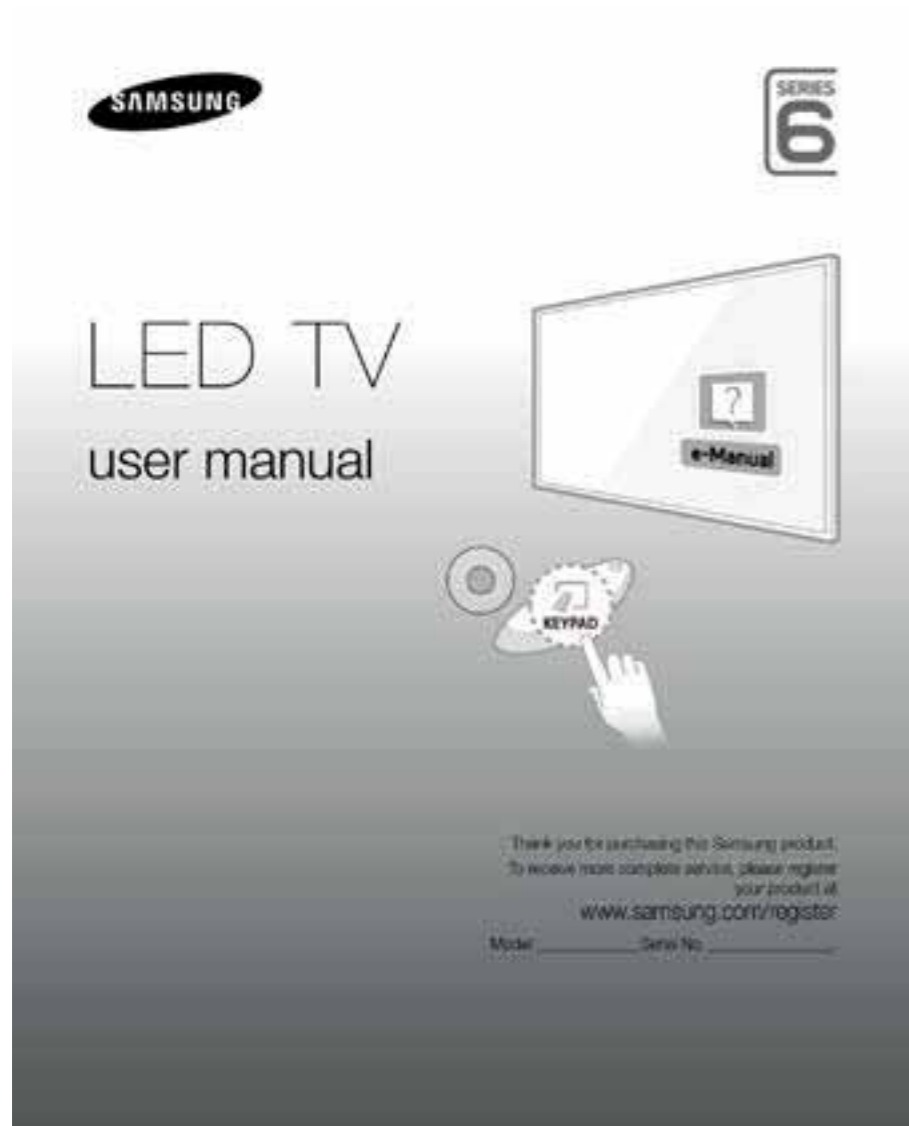

Rev.	Date	Prep.	Checked	Change						
01	20.05.2010	SEA			Initial drawing.					
<b>TANDBERG Telecom AS</b>					Sheet 1 of 1	Processes	Tolerances	Specification:	Material	Surface treatment
119952 rev.01					European projection	-	-	Type:	-	-
PrecisionHD 1080p 4x					Unit: mm	Dimensions without paint or finish		Manufacturer:	-	-
3D CAD model file 119952 rev. 01 is master					Sheet size: A3	All materials, finishes, and processes must comply with the RoHS directives		Type number:	-	-
					Scale: 1:5			Thickness:	-	-
					Part weight: g	Flame class requirement: -		Color:	-	-
								Surface:	-	-
								Glossiness:	-	-
								Flame class:	-	-
								UL reference:	-	-

# Appendix 1: AVL Studio Design – AVL Equipment

---

## Cisco TelePresence Table Microphone 20

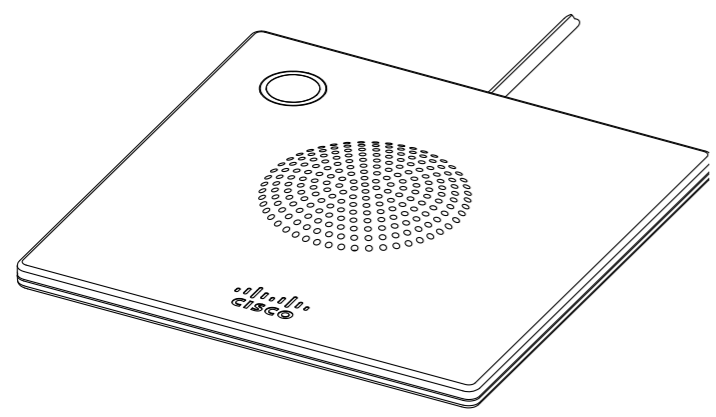
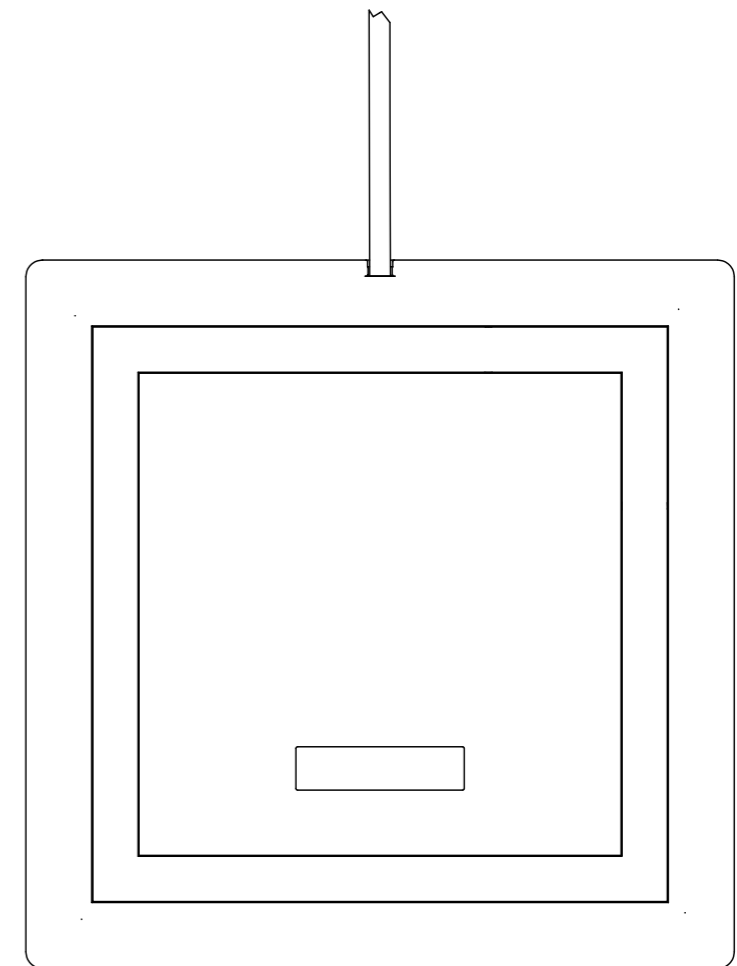
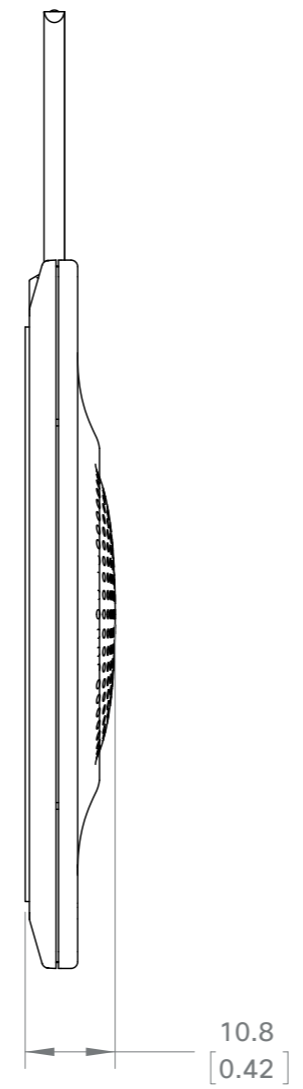
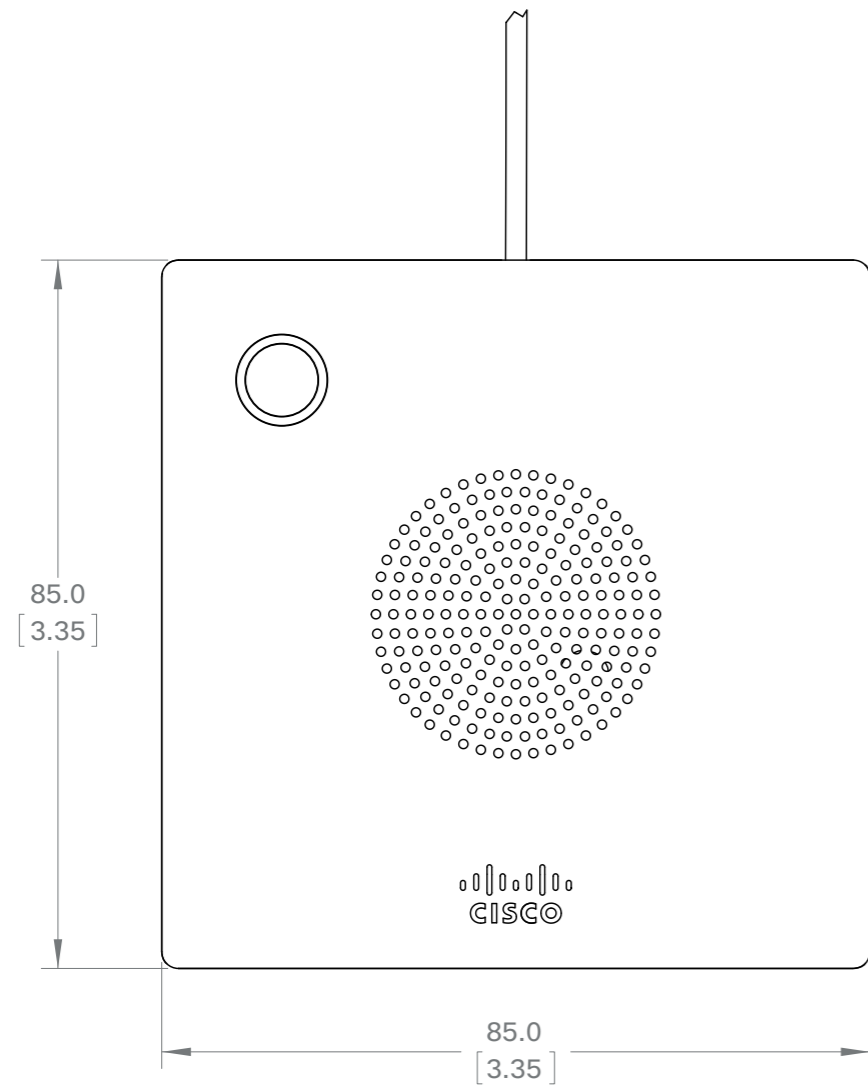

## COURT-CUSTODY AUDIO VISUAL LINKS

*Designing for equitable justice experiences in the use of court-custody video conferencing*

